

The better way to build™



Installation Manual

FOUNDATION SIPs & FROST WALLS SIPs



Thermapan
Structural
Insulated
Panels

PWF FOUNDATION & FROST WALL SIPs Installation Manual

Table of Contents

Topics

General Requirements	4
Terms	4
Materials	5
Site Preparation	6
Footings - Concrete	6
Foundation Columns	6
Exterior Walls	6
Concrete Slab Floors	7
Crawl Spaces	7
First Floors	7
Stairwell Openings	7
Support of Masonry Veneer	7
Exterior Moisture Barrier	8
PWF Wall to Existing Foundation	8
Electrical Wiring	8
Interior Finish	9
Frost Walls	9
Backfilling	9
Materials Estimation	10

PWF FOUNDATION & FROST WALL SIPs Installation Manual

Table of Contents

Details

Air Barrier Details for Air Barrier Sealants	AB-1
Air Barrier Details for Sealing PWF SIP Connections	AB-2
Vapour Barrier Details for Vapour Sealing PWF SIP Connections.	VB-1
Foundation Wall Lumber Spline Connections	FO-1
Typical Foundation Wall (Concrete Footing).	FO-2
Typical Foundation Wall (Preserved Wood Footing).	FO-3
Foundation Wall Assembly > 8' in Height.	FO-4
Crawl Space Wall Detail.	FO-5
Crawl Space Wall - Tundra Soil	FO-6
Foundation Corner Detail	FO-7
Point Load Detail - Wood Column	FO-8
Point Load Detail - Steel Column	FO-9
Suspended Floor Window Header Detail	FO-10
Suspended Floor Connections (Side Walls).	FO-11
Suspended Floor Connections (End Walls)	FO-12
Platform Floor Connections	FO-13
Stairwell Openings	FO-14
Corner Stairwell Openings & Framing Table	FO-15
Fastening PWF Wall to Existing Foundation.	FO-16
Electrical Installation	FO-17
Basement PWF Wall Connection to Frost Wall	FO-18
Brick Ledger Detail Secured to SIP Foundation	FO-19
Surcharge from Driveway Slab or Patio Slab	FO-20
Screw Fastener Detail - Securing Shelving to Foundation Panel.	FO-21
Frost Wall Details	FW-1
Frost Wall Panel Connections	FW-2
Frost Wall Point Load Detail.	FW-3
Fastening PWF Frost Wall to Existing Foundation	FW-4
Shallow Frost Wall	FW-5

FOUNDATION SIPs & FROST WALL SIPs Installation Manual

1. General Requirements

1.1 Scope

The basic design and construction requirements for the Thermapan Permanent Wood Structural Insulated Panel (PW SIP) foundation systems are set forth in this specification. Criteria for materials, preservative treatment, soil characteristics, environmental control, design loads, and structural design are included. Where requirements are based on internationally recognized standards and specifications, these standards and specifications are referenced without elaboration.

Installers shall reference engineering design package for fastening arrangements.

2. Terms

End Walls are the exterior walls parallel to the floor joists. They do not support the floor joists.

Side Walls are the exterior walls that are perpendicular to the floor joists.

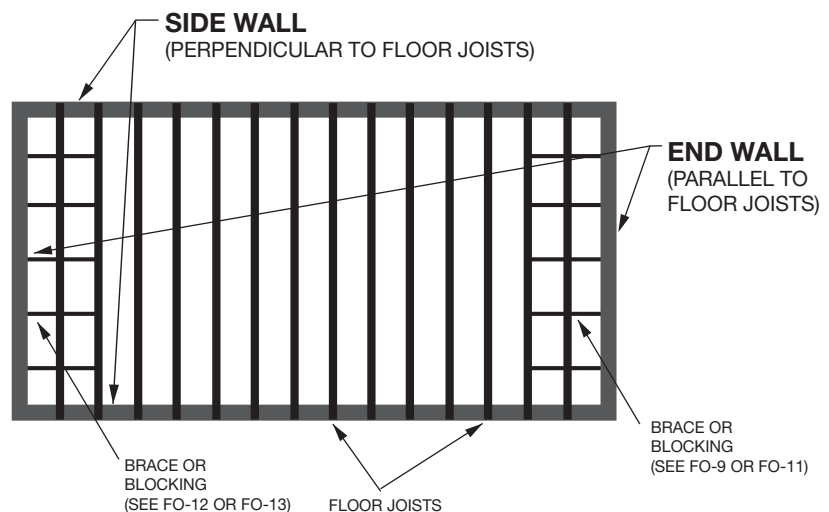

3. Materials

PW SIP Foundation Wall (See Figure FO-1)

- 3.1** The Thermapan PW SIP is composed of an expanded polystyrene (EPS) foam core laminated between two layers of preservative treated plywood with a structural adhesive.
- 3.2** Top Plate (**See Detail FO-1**). The top plate shall be untreated DOC PS 20 or NLGA No.2 or better.
- 3.3** Cap Plate (**See Detail FO-1**). The cap plate shall be untreated DOC PS 20 or NLGA No.2 or better. If the cap plate is to be used as a brick ledge, it shall be treated to AWPA U4B and CSA O080-08 U4B.
- 3.4** Framing Lumber shall be pressure treated DOC PS 20 or NLGA No.2 or better and shall be treated to AWPA U4B and CSA O080-08 U4B. Cut ends shall be treated with preservatives. (**See Detail FO-1**)
- 3.5** Fasteners and Connectors. Fasteners used shall be of Type 304, Type 316 stainless steel or ASTM A153 Hot Dip Galvanized. Connectors shall conform to ASTM A653.
- 3.6** Caulking Compounds shall conform to CAN/CGSB 19.13 or ASTM C 920.
- 3.7** Manufactured Drainage Layer shall conform to ICC-ES AC114.
- 3.8** Granular Drainage Layer shall consist of clean crushed stone or clean gravel which will pass through a 40 mm (1.5 in) sieve and contain not more than 10% of fine material that will pass a 4mm (0.15 in) sieve.
- 3.9** Low expansion foam seal shall conform to AAMA 812-04.

4. Site Preparation

- 4.1 Excavation requirements shall conform to those of the appropriate building code.
- 4.2 All top soil and vegetation matter that would be under the building must be removed.
- 4.3 The bottom of the excavation must be free of all organic matter and standing water.
- 4.4 A continuous granular drainage layer shall be installed under floors of PW-SIP-F's and not be less than 125mm (5").
- 4.5 The excavation and granular drainage layer shall drain to a sump, which shall be provided with positive drainage, by gravity or pump, to a final disposal point outside the building.
- 4.6 Perimeter drainage tile or pipe shall **NOT BE USED** with PW-SIP foundations.

5. Footings – Concrete

- 5.1 Concrete footings supporting PW SIP foundation walls shall be constructed in conformance with appropriate building code.
- 5.2 Concrete footings shall be placed on undisturbed soil or on 125mm (5") granular drainage layer. **See Detail FO-2 and FO-4.**
- 5.3 When concrete footings are placed on undisturbed soil, drainage shall be provided by casting 51mm (2") inner diameter water passages (pipes) at 1200mm (4') on centre in the footing. **See Detail FO-2 and FO-4.**
- 5.4 Concrete footings shall be designed for point loads. **See Details FO-8 and FO-9.**
- 5.5 The use of any drainage tile or pipe will void the Thermapan warranty.

6. Foundation Columns

Columns supporting floor beams and/or point loads above shall be constructed in conformance with appropriate building code.
See Details FO-8 and FO-9

7. Exterior Walls

Framing and fastening around wall openings shall conform to **Detail FO-10**

8. Concrete Slab Floors

Concrete slab floors shall not be less than 75mm (3") thick exclusive of concrete topping.

Ensure the edge of the concrete slab is finished to a smooth, uniform surface to provide full lateral support at the base of the PWF wall. The slab edge must be continuous and level to prevent uneven surface and to enhance structural stability.

See Detail FO-2, FO-3 and FO-4.

9. Crawl Spaces

Crawl spaces (with no concrete slab) shall be backfilled and compacted to a minimum of 2/5 of the exterior backfill height for lateral support and lined with a poly ground cover. **See Detail FO-5.**

10. First Floors

- 10.1** The first floor system is an integral part of the entire foundation.
- 10.2** Floor at the top of the foundations shall be constructed to prevent inward movement of the exterior walls due to lateral pressure.
- 10.3** A PW-SIP foundation shall never be backfilled before the entire first floor system (joists, subfloor, etc.) and basement floor are completely installed.
- 10.4** Support for side walls see **Detail FO-11.**
- 10.5** Support for end walls see **Detail FO-12.**
- 10.6** When the backfill heights are at different heights around the building, additional nailing requirements must be incorporated for the foundation wall sheathing.

11. Stairwell Openings

- 11.1** When openings are greater than 1200mm (4') from a side wall and 1800mm (6') from an endwall, stairwell opening construction shall conform to the minimum requirements for wood frame construction in the appropriate building code.
- 11.2** When openings are closer to their adjacent walls than specified previously, they shall conform to the following **Details FO-13 and FO-14.**

**12. Support of
Masonry Veneer**

See Detail FO-11 or FW-1.

13. Exterior Moisture Barrier

See Detail FO-2, FO-3 and FO-4.

13.1 The below grade portion of the exterior face of the wall sheathing on a PW-SIP foundation enclosing living space shall be protected by a moisture barrier and manufactured drainage layer.

13.2 A manufactured drainage layer shall be applied over the exterior wall sheathing and at the soil grade. The manufactured drainage layer is to be installed as per the manufacturer's instructions.

13.3 The manufactured drainage layer shall cover the entire surface below grade and extend to the bottom edge of the concrete footing. It shall not obstruct the required drainage passages

13.4 The adherence of any water-proofing membrane to any Thermapan SIP PWF plywood surface will void the Thermapan warranty.

**14. PWF Wall to
Existing Foundation**

See Detail FO-16.

15. Electrical Wiring

15.1 All wire chases to be vertically cut into the PW-SIP at a minimum depth of 2". See Detail FO-17.

15.2 All electrical boxes shall be plastic.

15.3 All fasteners shall be of Type 304, Type 316 stainless steel or ASTM A153 Hot Dip Galvanized.

16. Interior Finish

The interior of the PW-SIP foundation can be finished with any of the common materials. The interior plywood of the SIP makes this a relatively simple operation without consuming floor area as would be the case with other types of foundations that require interior wood frame walls to be built before finishing.

17. Frost Walls

See Details FW-1, FW-2, FW-3, FW-4 and/or FW-5.

18. Backfilling

- 18.1** PWF SIP foundations shall not be backfilled until the basement floor slab and the floor on top of the foundation are completely installed.
- 18.2** Heavy equipment and loads shall be kept a safe distance from foundations.
- 18.3** Backfill shall be placed in uniform lifts not exceeding 600mm (2') around the foundation.
- 18.4** The site shall be graded sloping away from the foundation or to appropriate building code.
- 18.5** For additional backfilling and site drainage details beyond this manual refer to your local building code and the following building standards: 1) Canada – CAN/CSA-S406-92 Construction of Preserved Wood Foundations and 2) USA - ANSI / AWC PWF-2015 - Permanent Wood Foundation Design Specification.

MATERIALS ESTIMATING

Foundations/Frost Walls Estimation Only

Lumber Requirements:

- Single bottom plate: 14ft (4268mm) or 16ft (4678mm) lengths are best
- Single top plates plus a cap plate can be SPF unless siding is brick and backfill height is less than 12" (300mm) from top of the panel use PWF
- Every panel requires 2 studs
- Every corner requires 2 studs
- Calculate number of outside corners – every 4 requires a sheet of PWF Plywood

Caulking and Sealant Requirements:

- Every 1200 sqft (111 m²) of SIP equals 1 case of Expandable Foam
- Every 2000 sqft (185 m²) of SIP requires 1 case of Sealant

Fasteners:

- Recommend 2" (50mm) nails/screws
- 3.0 times sqft of panel equals number of fasteners
- All floor joists require framing straps [e.g. USP PWFS24]

AIR BARRIER

RECOMMENDED DETAILS FOR AIR BARRIER SEALANTS

All sealants, FOAM (A) or CAULKING (B), should be applied onto the SIP in a continuous rectangular pattern along the outer most edge of the area to be sealed.

(A) A low expansion EXPANDABLE FOAM SEALANT should conform to the AAMA 812-04 standard. Apply a 1/2 inch or a 12.5 mm diameter of a *continuous* bead of expandable foam sealant onto the SIP:

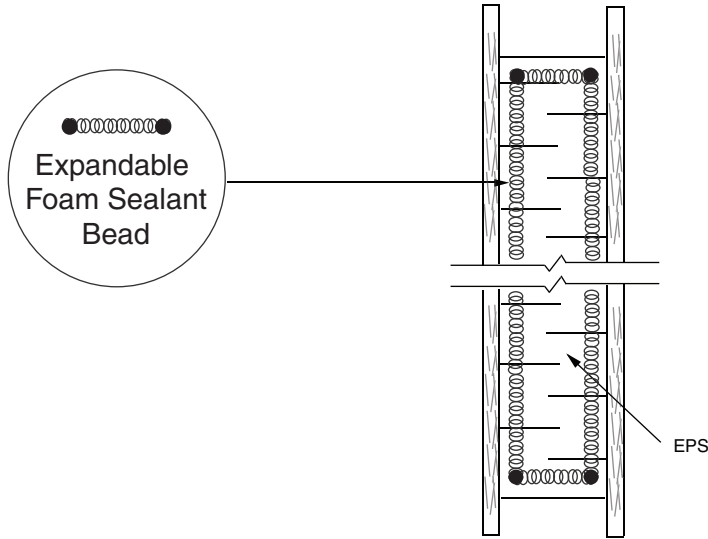

(B) A CAULKING SEALANT should conform to ASTM C920-02 and/or CAN/CGSB 19.13-M. Apply a 3/8 inch or a 10 mm diameter *continuous* bead of caulking onto the lumber spline:

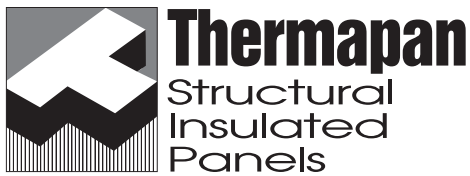
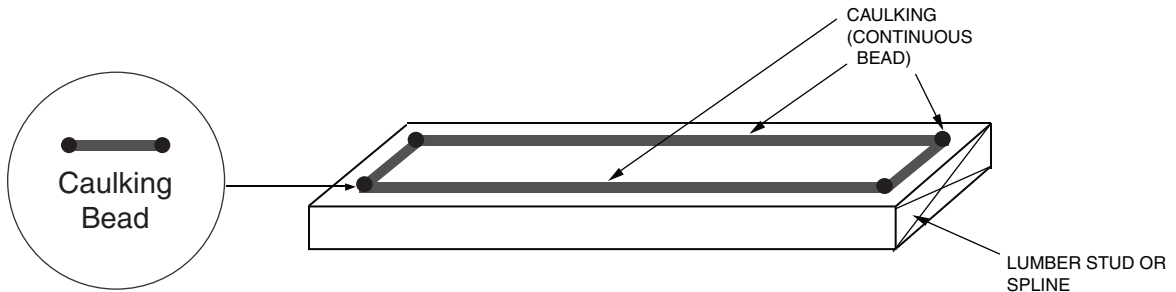

www.thermapan.com
1-877-443-WALL (9255)

TITLE	AIR BARRIER DETAILS FOR AIR BARRIER SEALANTS		PROJECT
REFERENCE	SCALE N.T.S.		
DATE	REVISION	DWG. No.	
NOVEMBER 2010	1	AB-1	

AIR BARRIER

RECOMMENDED DETAILS FOR SEALING SIP CONNECTIONS

(1) Wood to Wood Spline Joint: Use caulking and a low expansion foam sealant.

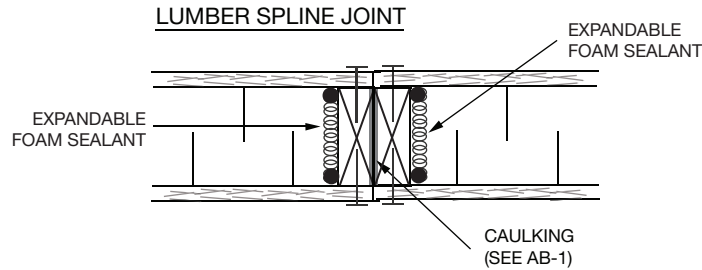

(2) Foam to Wood: Use a low expansion foam sealant.

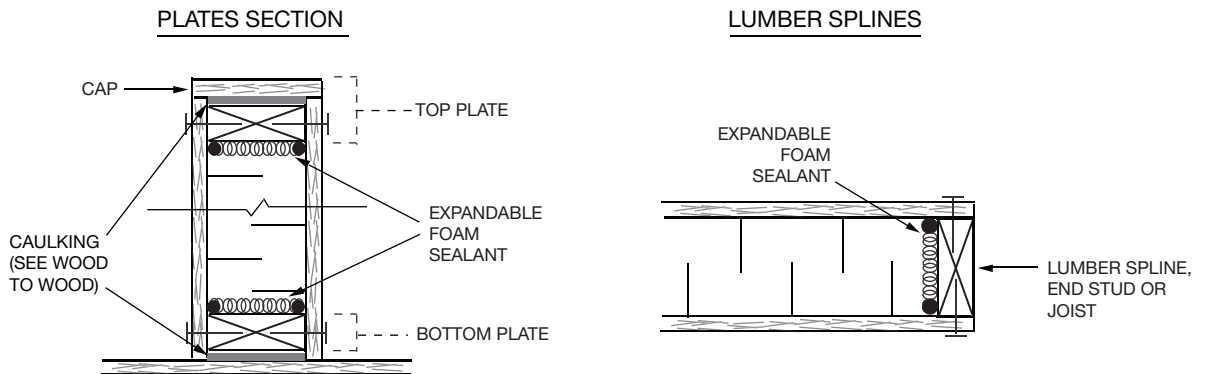

(3) Wood to Wood Corner: Use caulking and a low expansion foam sealant.

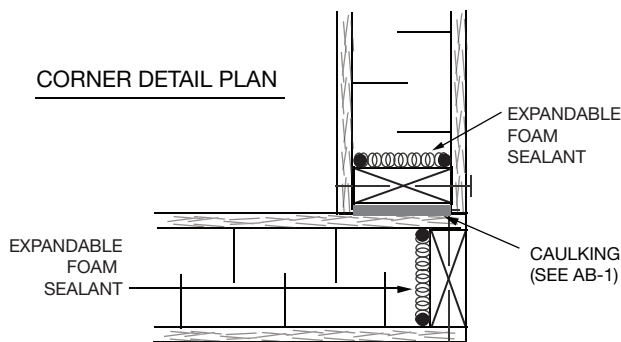

www.thermapan.com
1-877-443-WALL (9255)

TITLE		PROJECT	
AIR BARRIER DETAILS FOR SEALING PWF SIP CONNECTIONS		PROJECT	
		SCALE	
REFERENCE	N.T.S.		
DATE	REVISION	DWG. No.	
JUNE 2020		AB-2	

VAPOUR BARRIER

RECOMMENDED DETAILS FOR VAPOUR SEALING SIP CONNECTIONS

The function of a vapour barrier is to control the entry of water vapour into the building assembly. Vapour barriers should not be confused with an air barrier.

All SIP seams and connections must be VAPOUR SEALED from the INTERIOR.

These are recommended vapour barrier methods:

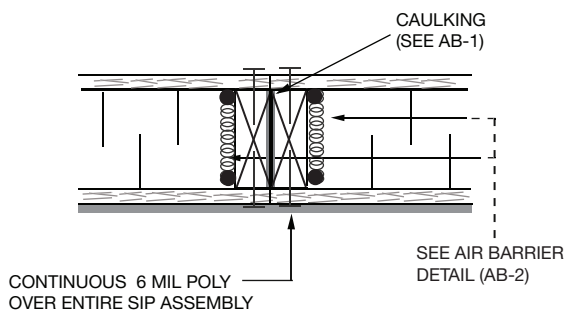

CONTINUOUS 6 MIL POLY
RECOMMENDED

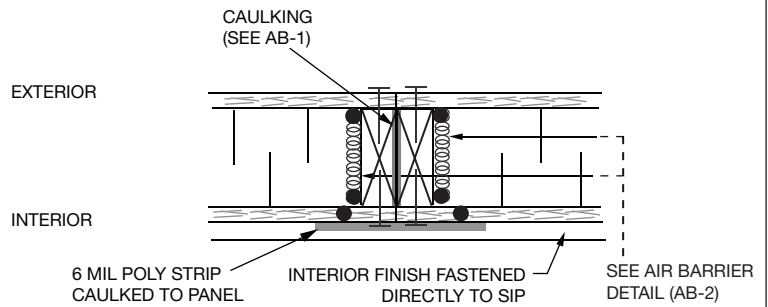

6 MIL POLY STRIPS & CAULKING

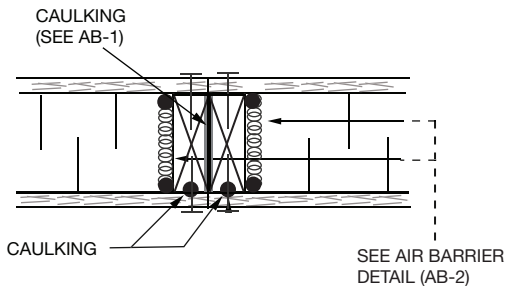

CAULKING

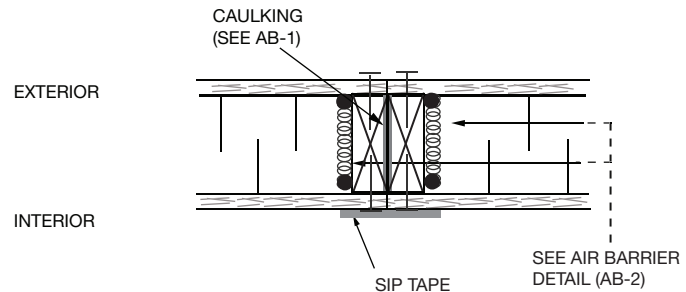

SIP TAPE



www.thermapan.com
1-877-443-WALL (9255)

TITLE		PROJECT	
VAPOUR BARRIER DETAILS FOR VAPOUR SEALING PWF SIP CONNECTIONS			
REFERENCE	SCALE		
	N.T.S.		
DATE	REVISION	DWG. No.	
JUNE 2020		VB-1	

ISOMETRIC VIEW

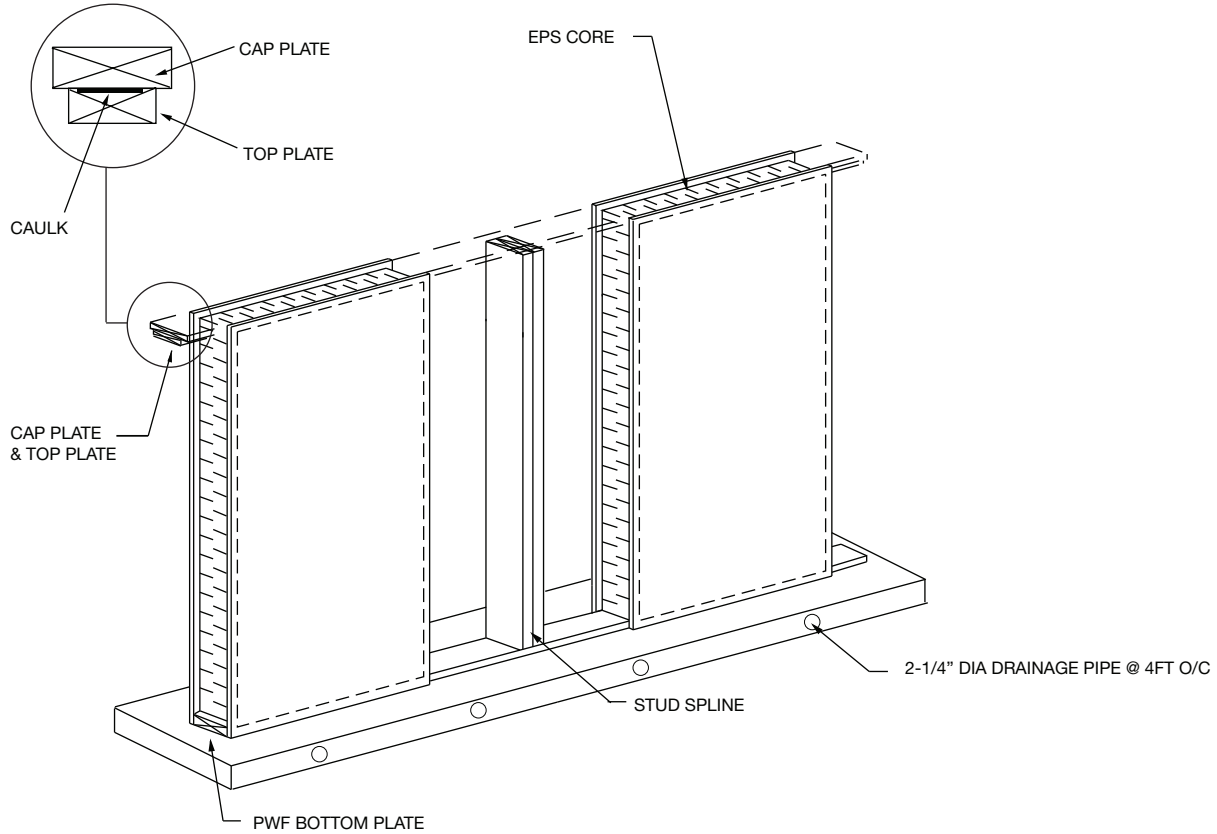

TOP PLAN

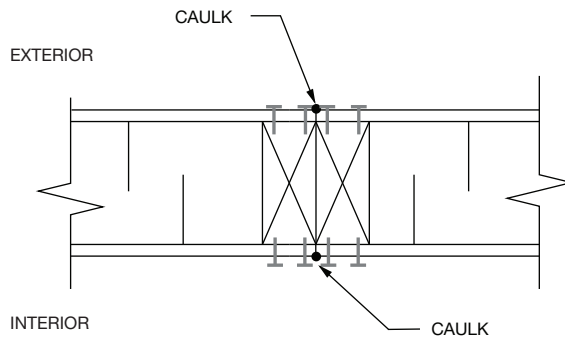

NOTES: REFER TO AIR BARRIER (AB-1) DETAILS FOR SEALING SIP CONNECTIONS.

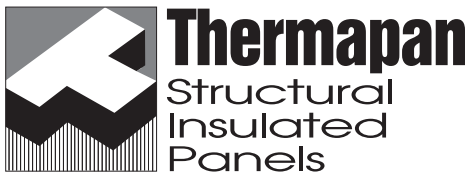

www.thermapan.com
1-877-443-WALL (9255)

TITLE		PROJECT	
FOUNDATION WALL LUMBER SPLINE CONNECTIONS		PROJECT	
		REFERENCE	
DATE		SCALE	DWG. No.
MAY 2023		N.T.S.	
REVISION		5	

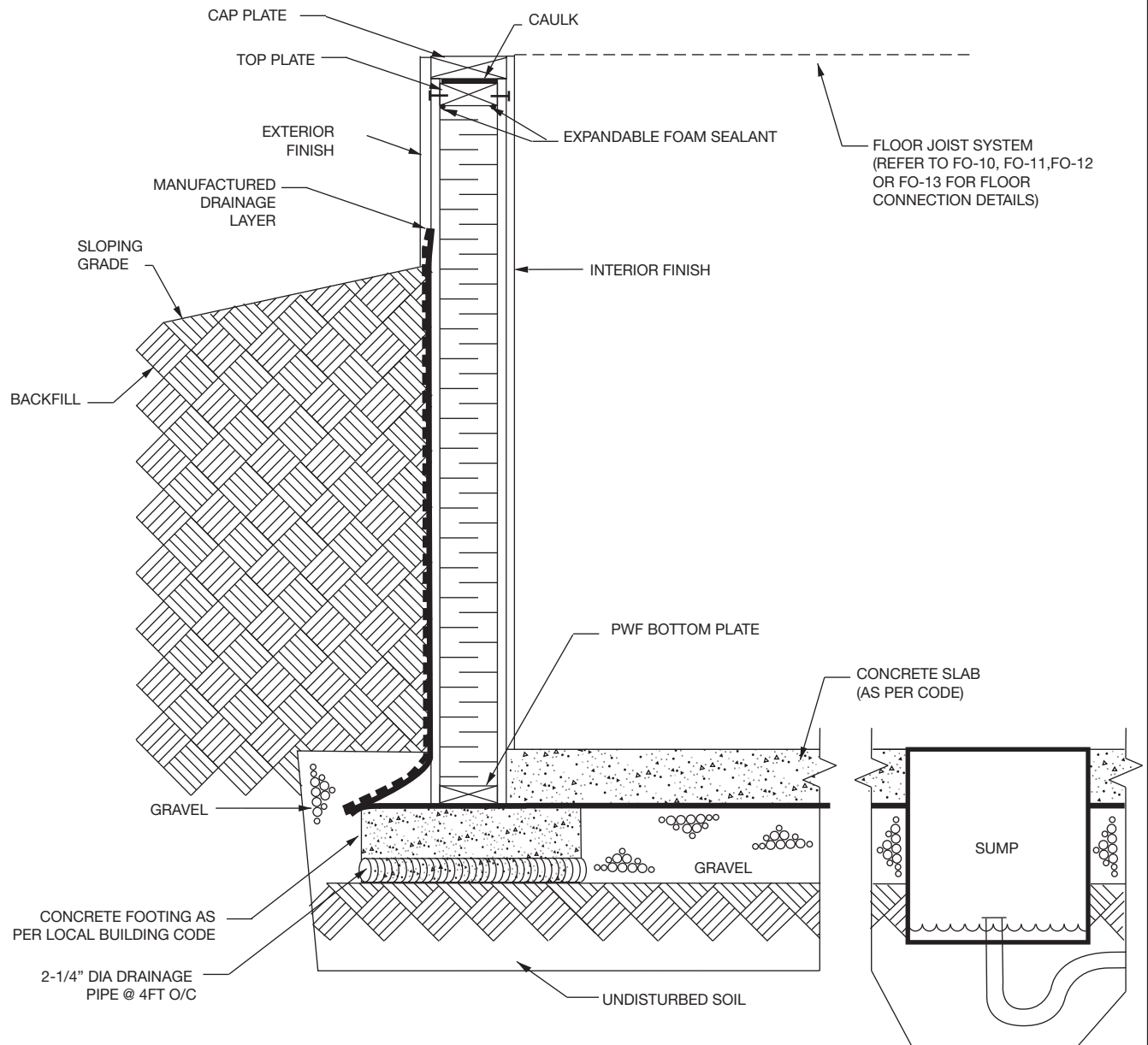

NOTES: THE ADHERENCE OF ANY WATER-PROOFING MEMBRANE TO ANY THERMAPAN SIP PWF PLYWOOD SURFACE WILL VOID THE THERMAPAN WARRANTY
REFER TO AIR BARRIER (AB-1) DETAILS FOR SEALING SIP CONNECTIONS.



www.thermapan.com
1-877-443-WALL (9255)

TITLE		PROJECT	
TYPICAL FOUNDATION WALL (CONCRETE FOOTING)			
REFERENCE	SCALE		
	N.T.S.		
DATE	REVISION	DWG. NO.	
MAY 2023	4	FO-2	

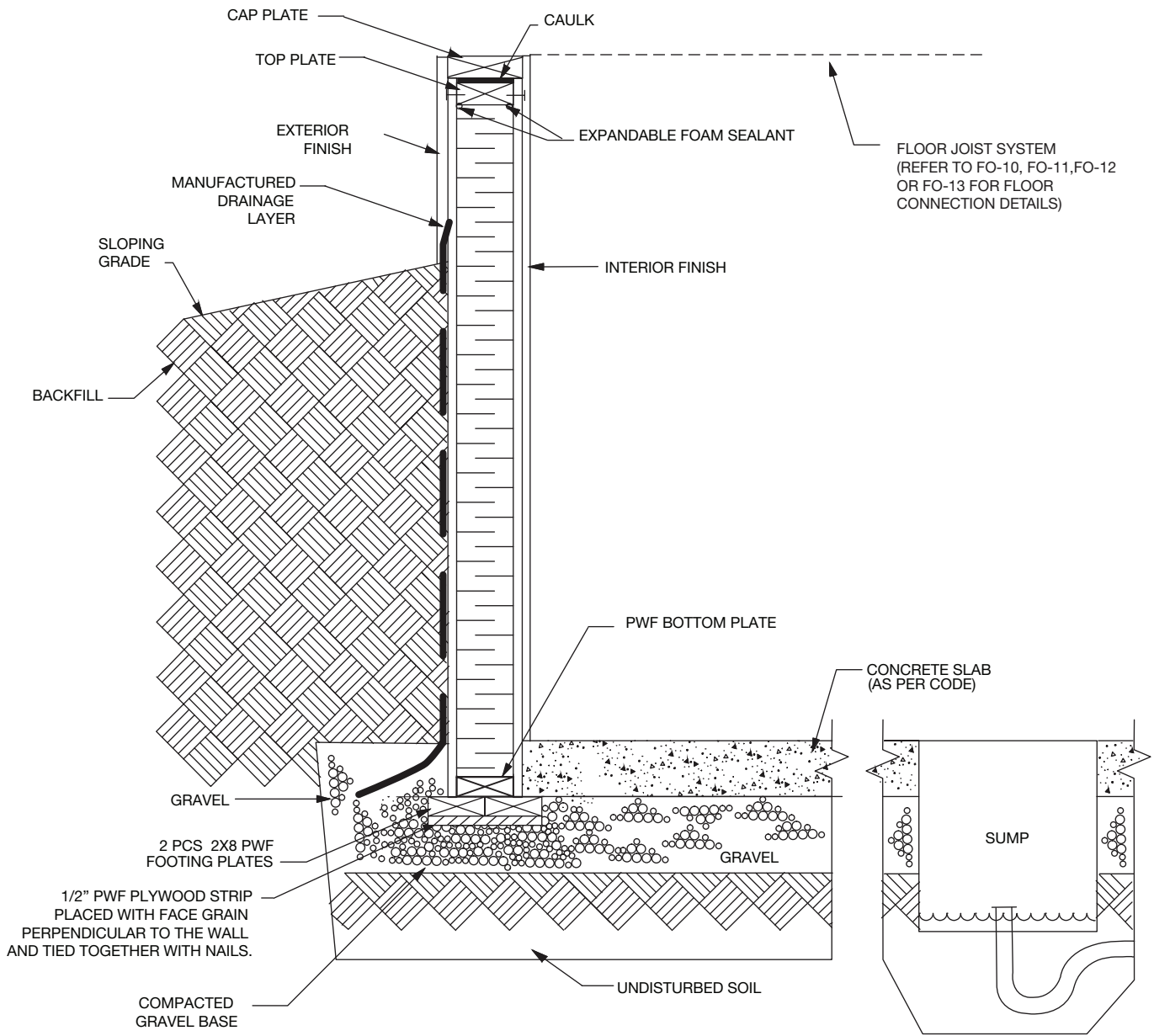

NOTES: THE ADHERENCE OF ANY WATER-PROOFING MEMBRANE TO ANY THERMAPAN SIP PWF PLYWOOD SURFACE WILL VOID THE THERMAPAN WARRANTY
REFER TO AIR BARRIER (AB-1) DETAILS FOR SEALING SIP CONNECTIONS.

 <p>www.thermapan.com 1-877-443-WALL (9255)</p>	TITLE		PROJECT	
	TYPICAL FOUNDATION WALL (PRESERVED WOOD FOOTING)			
	REFERENCE	SCALE		
DATE	MAY 2023	REVISION	DWG. NO.	
		4	FO-3	

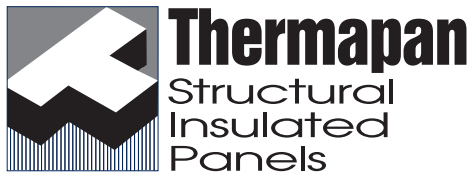
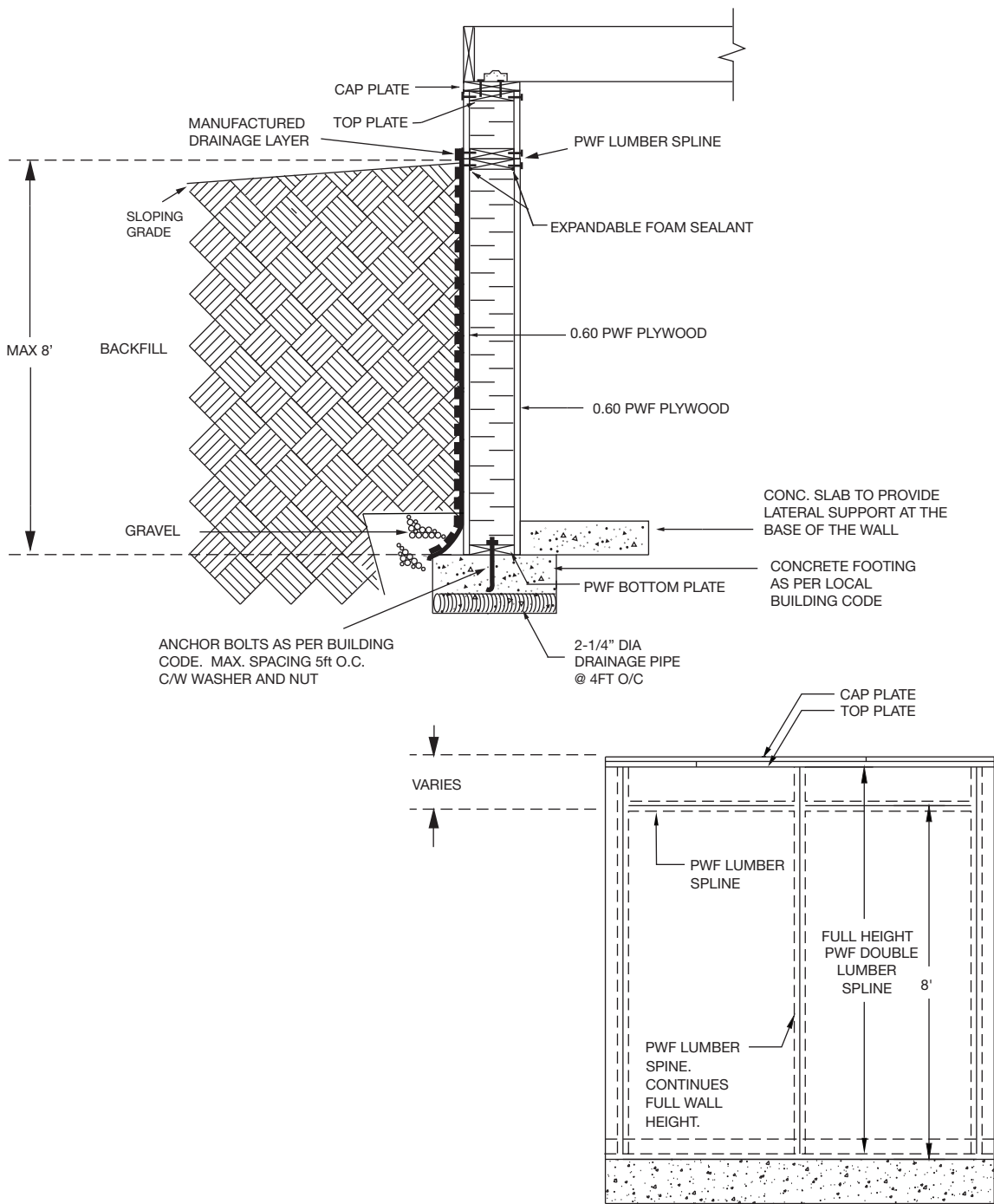

www.thermapan.com
1-877-443-WALL (9255)

TITLE		PROJECT	
FOUNDATION WALL ASSEMBLY > 8'0 IN HEIGHT			
REFERENCE	SCALE		
	N.T.S.		
DATE	REVISION	DWG. No.	
SEPTEMBER 2024	2	FO-4	

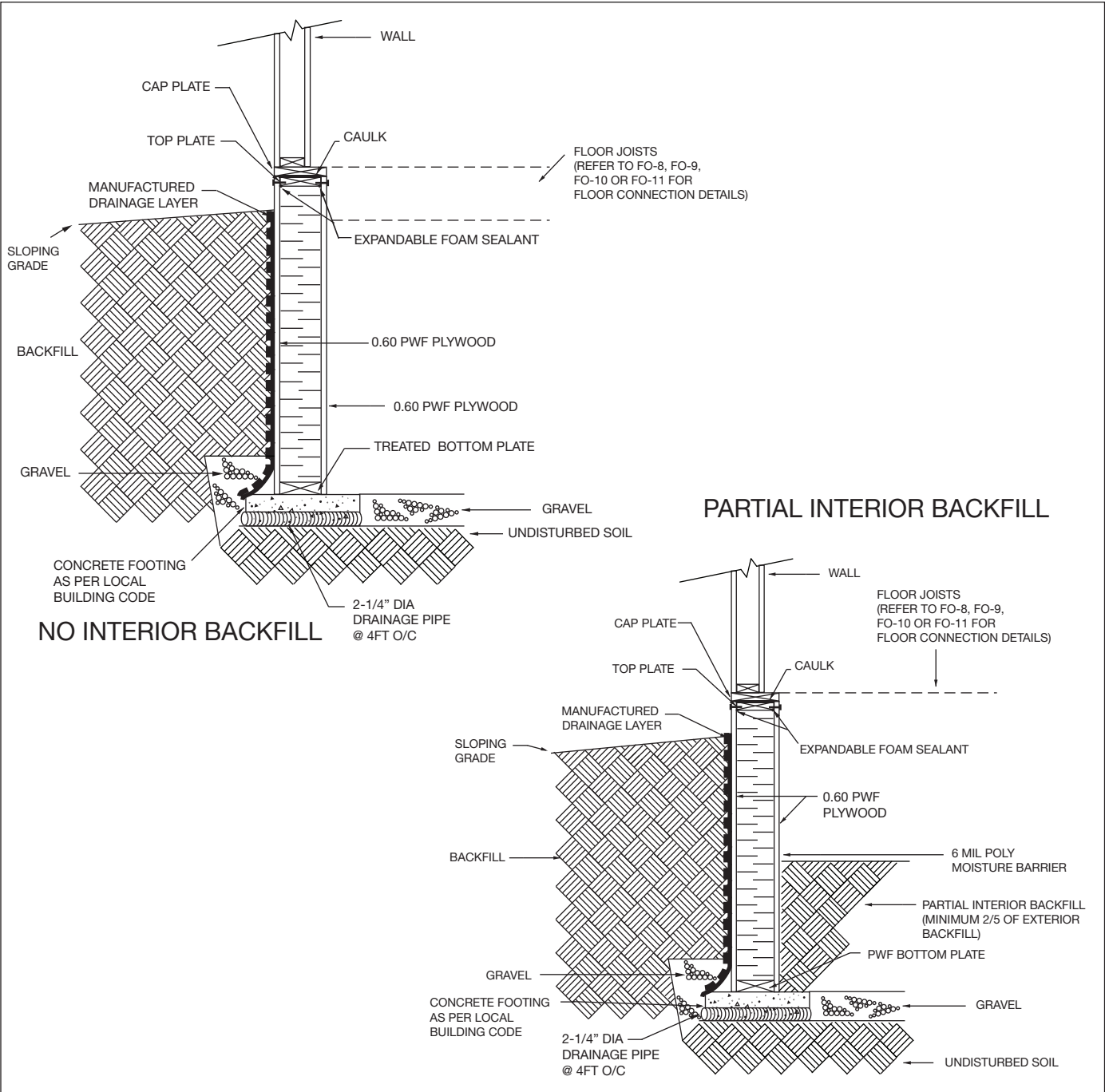

NOTE: THE ADHERENCE OF ANY WATER-PROOFING MEMBRANE TO ANY THERMAPAN SIP PWF PLYWOOD SURFACE WILL VOID THE THERMAPAN WARRANTY.
 REFER TO AIR BARRIER (AB-1) DETAILS FOR SEALING SIP CONNECTIONS.



www.thermapan.com
 1-877-443-WALL (9255)

TITLE		PROJECT	
CRAWL SPACE WALL DETAIL			
REFERENCE	SCALE		
	N.T.S.		
DATE	REVISION	DWG. No.	
MAY 2023	5	FO-5	

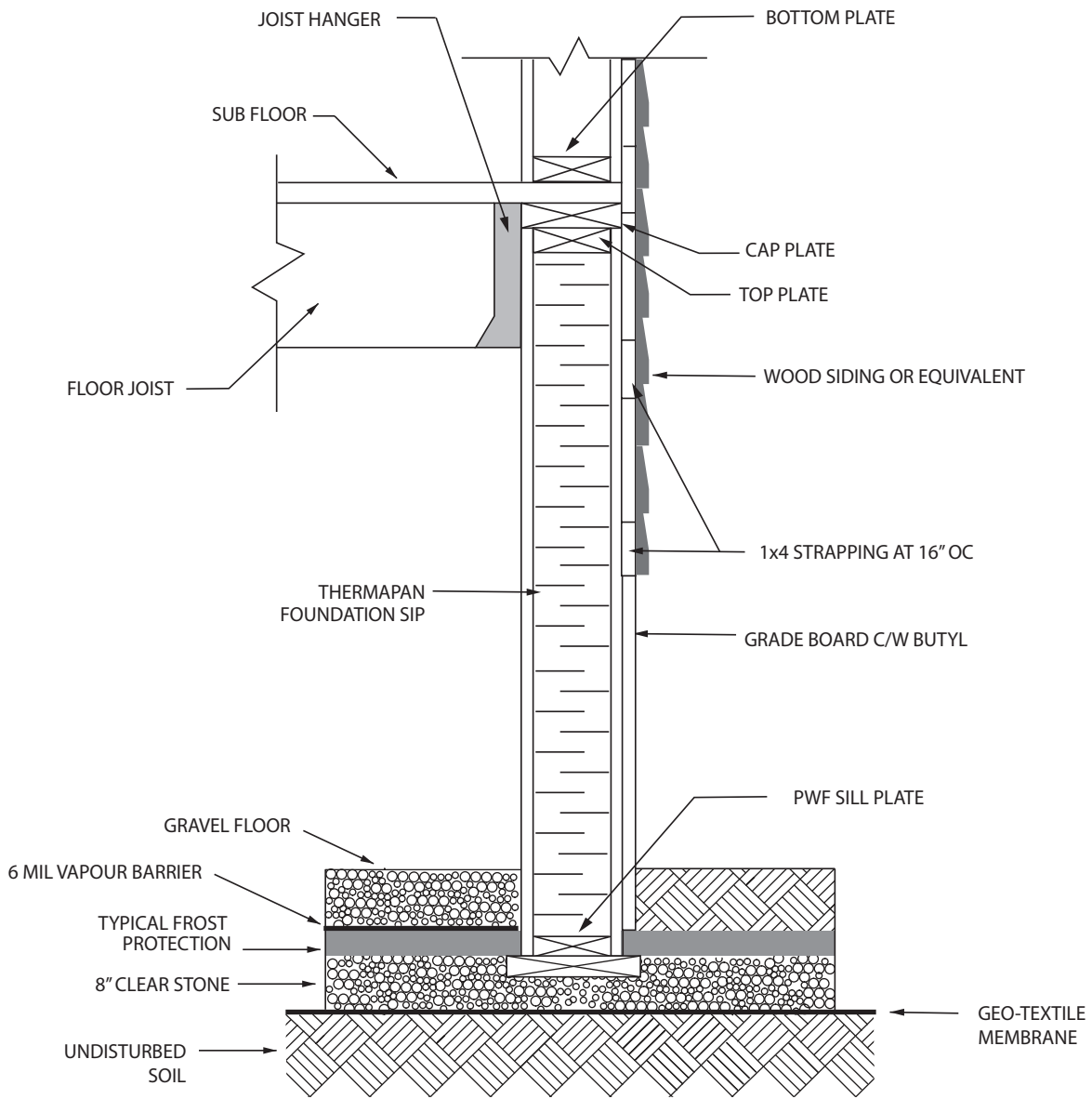

NOTE: THE ADHERENCE OF ANY WATER-PROOFING MEMBRANE TO ANY THERMAPAN SIP PWF PLYWOOD SURFACE WILL VOID THE THERMAPAN WARRANTY.

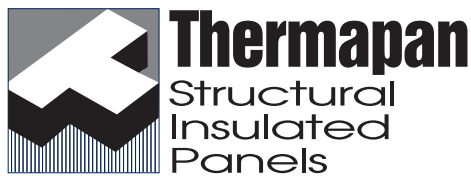

www.thermapan.com
1-877-443-WALL (9255)

TITLE		PROJECT	
CRAWL SPACE WALL – TUNDRA SOIL			
REFERENCE	SCALE		
	N.T.S.		
DATE	REVISION	DWG. No.	
MARCH 2021		FO-6	

CAP PLATE & TOP PLATE
(CORNER DETAIL)

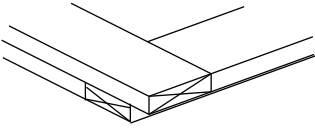

ISOMETRIC VIEW

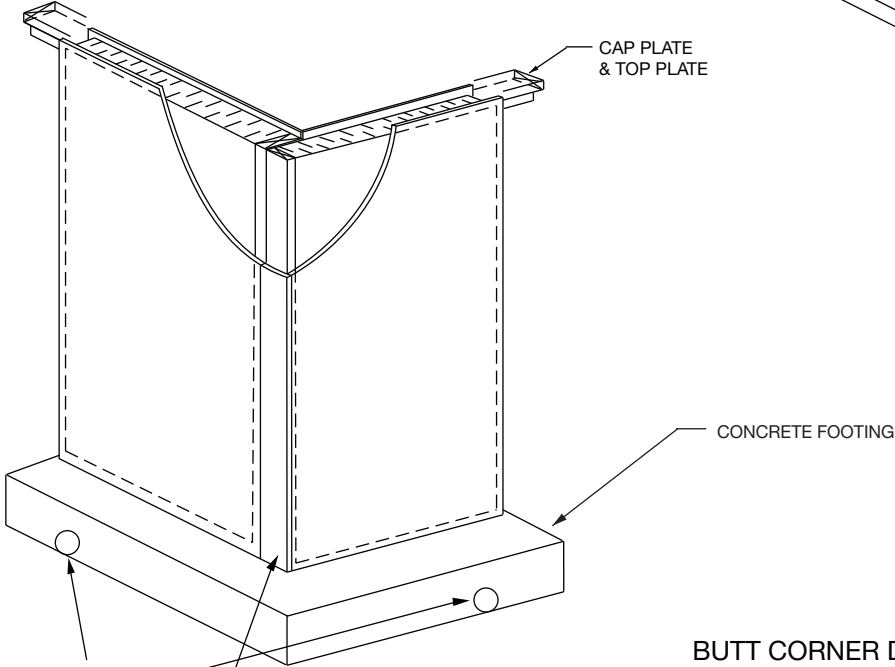

2-1/4" DIA
DRAINAGE PIPE
@ 4FT O/C

PWF PLYWOOD
STRIP

EXPANDABLE FOAM
SEALANT

PWF PLYWOOD JOINT AT
HALF OF END STUD

2" (50 mm) NAILS
AT 8" (200 mm) O/C

CAULK

BUTT CORNER DETAIL

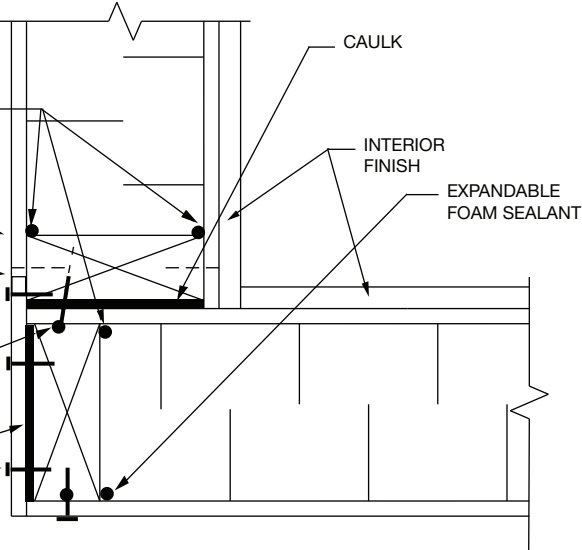

Thermapan
Structural
Insulated
Panels

www.thermapan.com
1-877-443-WALL (9255)

TITLE			FOUNDATION CORNER DETAIL		
REFERENCE		SCALE			
		N.T.S.			
DATE		REVISION	DWG. NO.		
FEBRUARY 2012		2	FO-7		

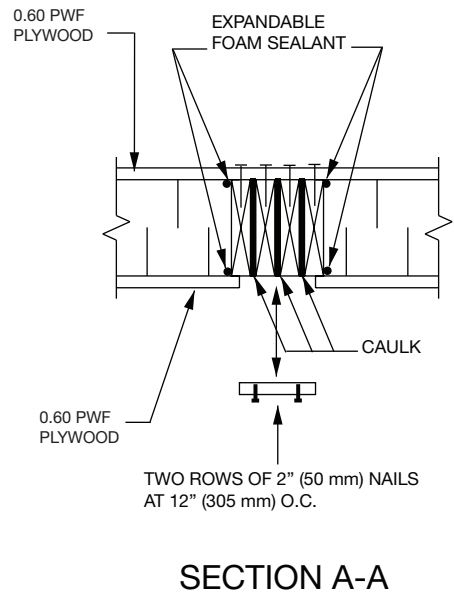
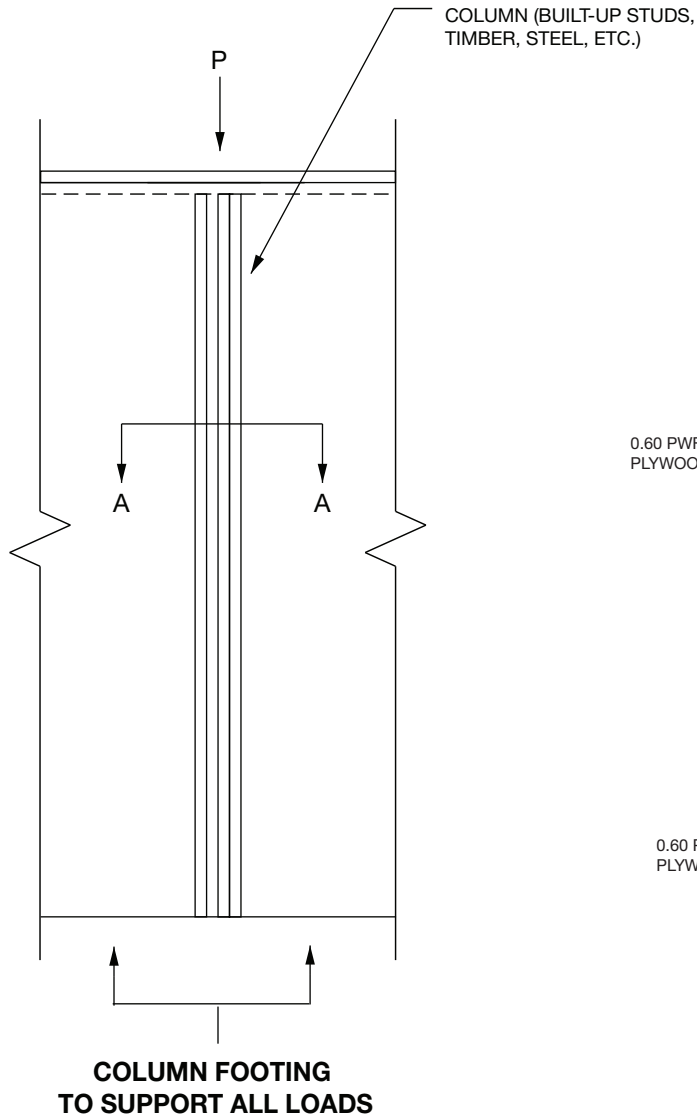

NOTES: COLUMNS SUPPORTING FLOOR BEAMS SHALL BE CONSTRUCTED IN CONFORMANCE WITH LOCAL BUILDING CODE.

REFER TO AIR BARRIER (AB-1) DETAILS FOR SEALING SIP CONNECTIONS.

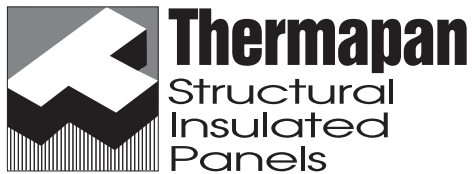

www.thermapan.com
1-877-443-WALL (9255)

TITLE		PROJECT	
POINT LOAD DETAIL - WOOD COLUMN			
REFERENCE	SCALE		
	N.T.S.		
DATE	REVISION	DWG. No.	
NOVEMBER 2011	2	FO-8	

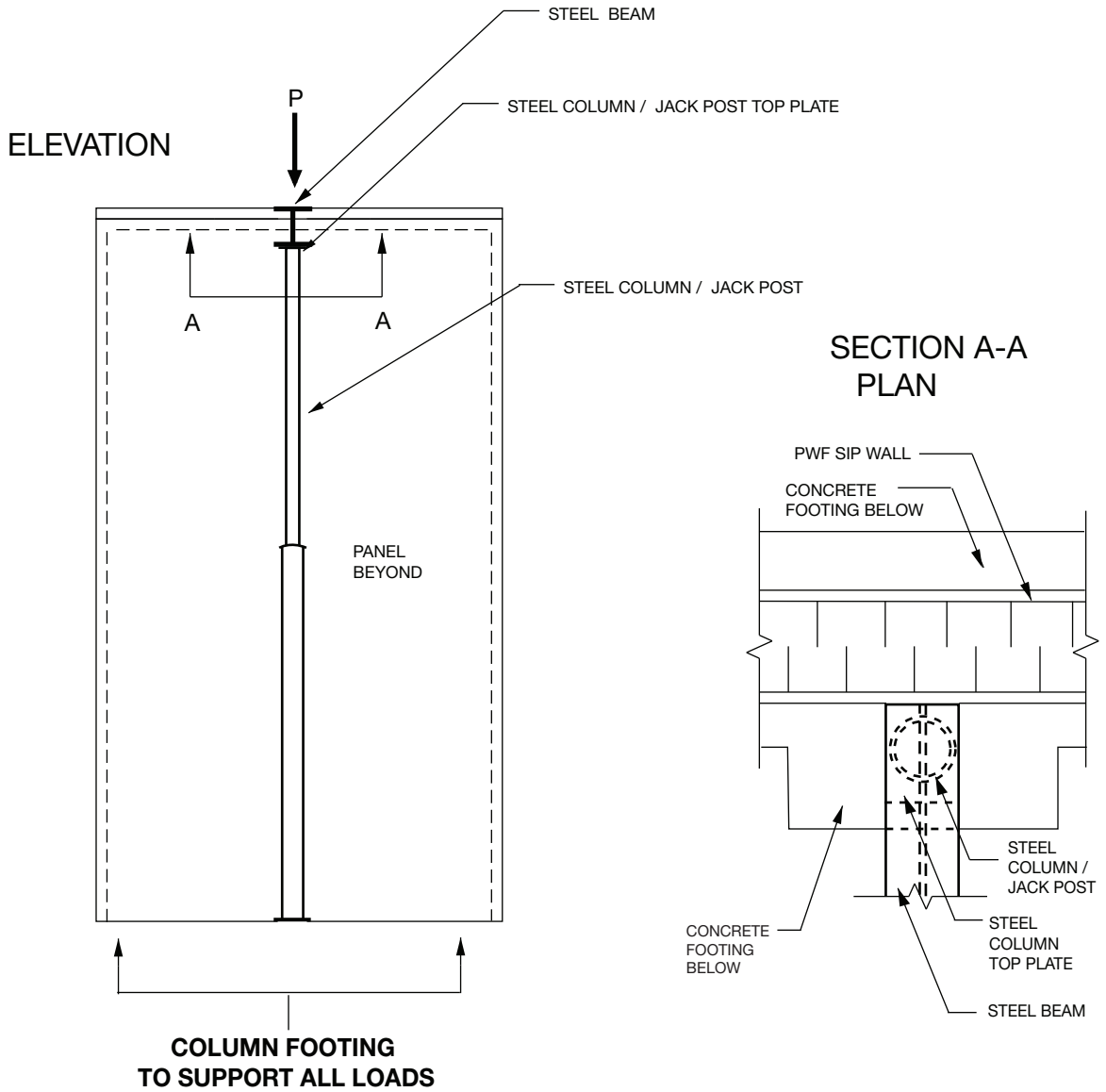

NOTE: COLUMNS SUPPORTING FLOOR BEAMS AND FOOTINGS SHALL CONFORM WITH LOCAL BUILDING CODE.

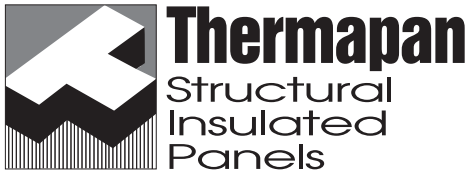

www.thermapan.com
1-877-443-WALL (9255)

TITLE		PROJECT	
POINT LOAD DETAIL - STEEL COLUMN			
REFERENCE	SCALE		
	N.T.S.		
DATE	REVISION	DWG. No.	
MAY 2011	1	FO-9	

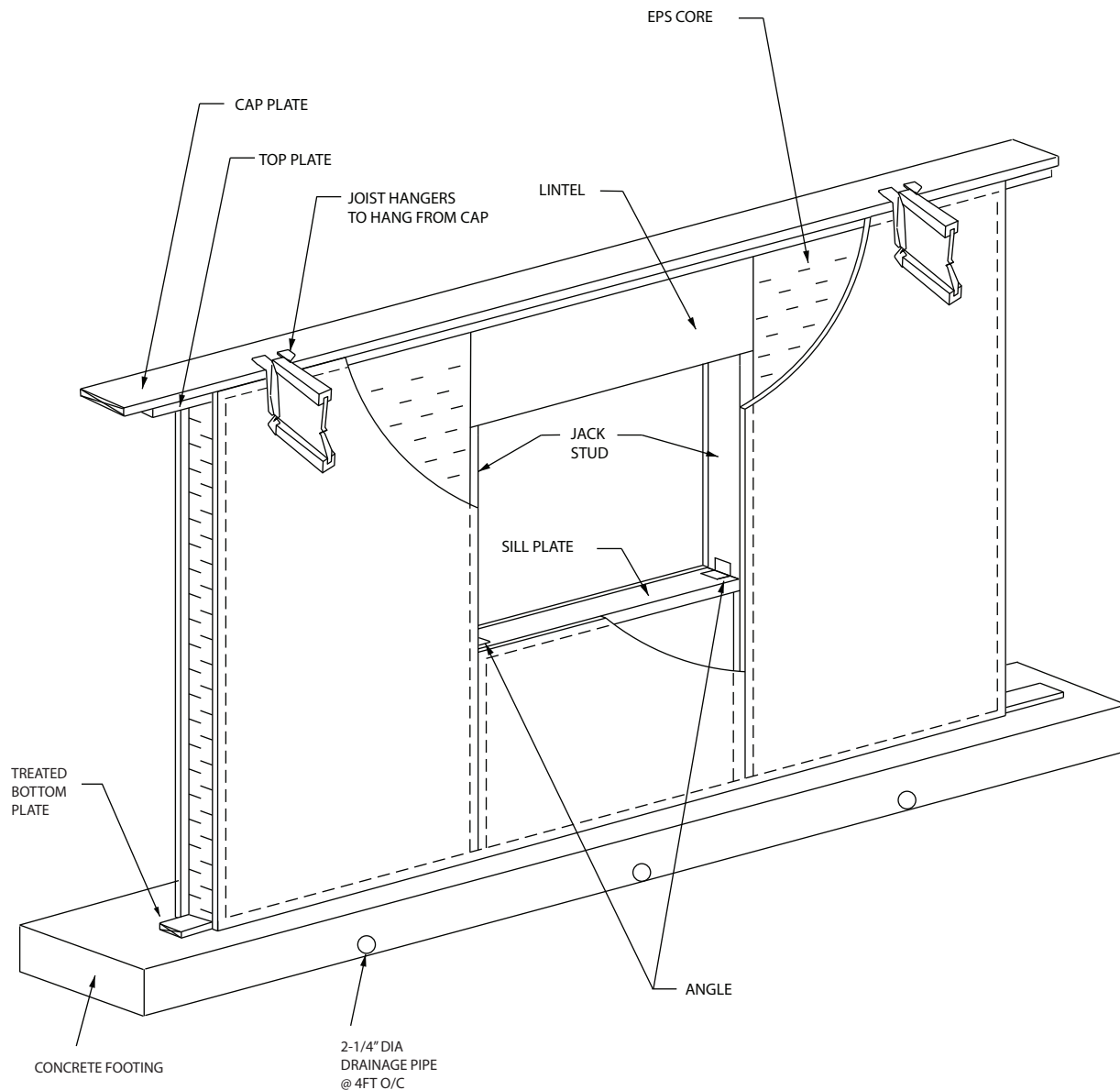

NOTES: REFER TO AIR BARRIER (AB-1) DETAILS FOR SEALING SIP CONNECTIONS.

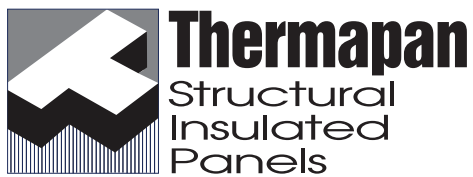

www.thermapan.com
1-877-443-WALL (9255)

TITLE

SUSPENDED FLOOR
WINDOW HEADER DETAIL

REFERENCE

SCALE

N.T.S.

DATE

SEPTEMBER 2018

REVISION

3

DWG. No.

FO-10

SUSPENDED FLOOR DETAIL

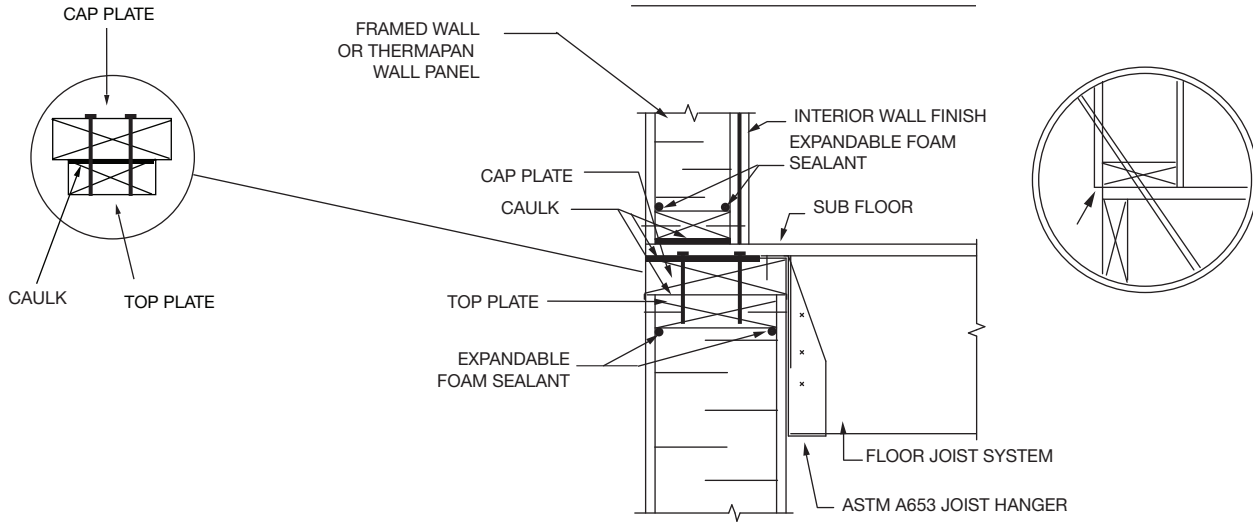

**SUSPENDED FLOOR DETAIL
(BRICK VENEER/PANEL FOUNDATION)**

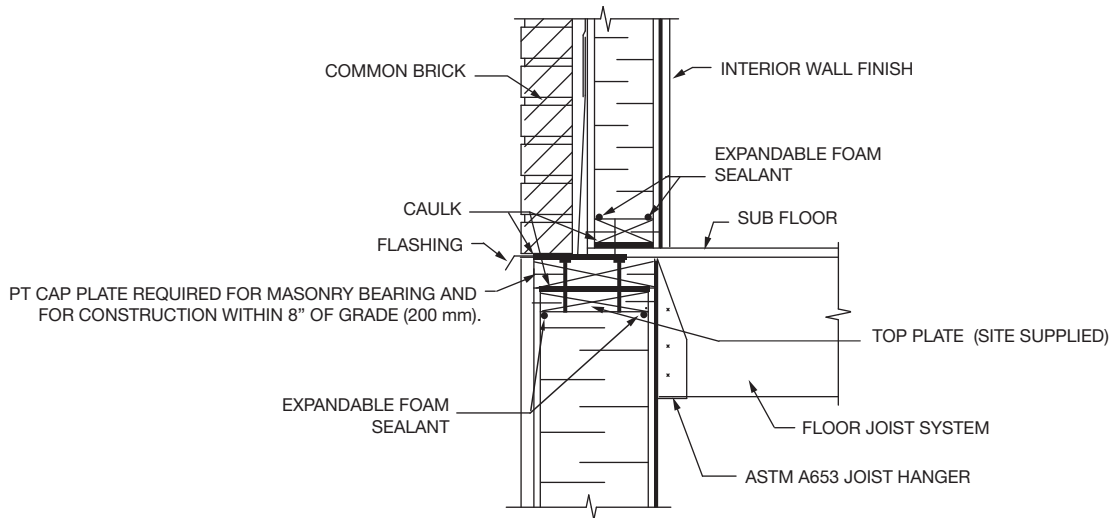

NOTES: REFER TO AIR BARRIER (AB-1) DETAILS FOR SEALING SIP CONNECTIONS.

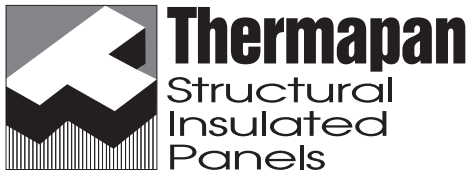

www.thermapan.com
1-877-443-WALL (9255)

TITLE		PROJECT	
SUSPENDED (HUNG) FLOOR CONNECTIONS (SIDE WALLS)		PROJECT	
REFERENCE	SCALE		
	N.T.S.		
DATE	REVISION	DWG. No.	
FEBRUARY 2012	2	FO-11	

WOOD I-JOIST FLOOR DETAIL
(WOOD I-JOIST INSTALLATION TO
BE CONFIRMED BY JOIST MANUFACTURER)

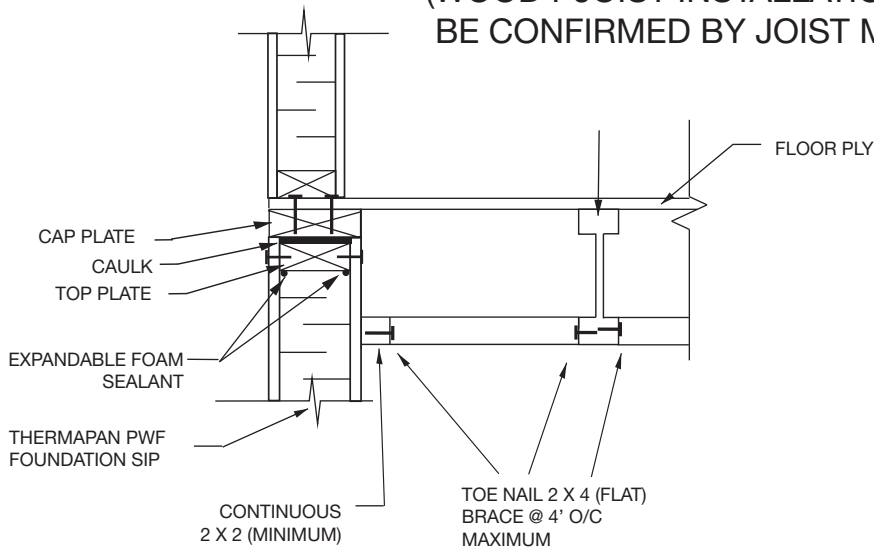

2X_ JOIST FLOOR DETAIL

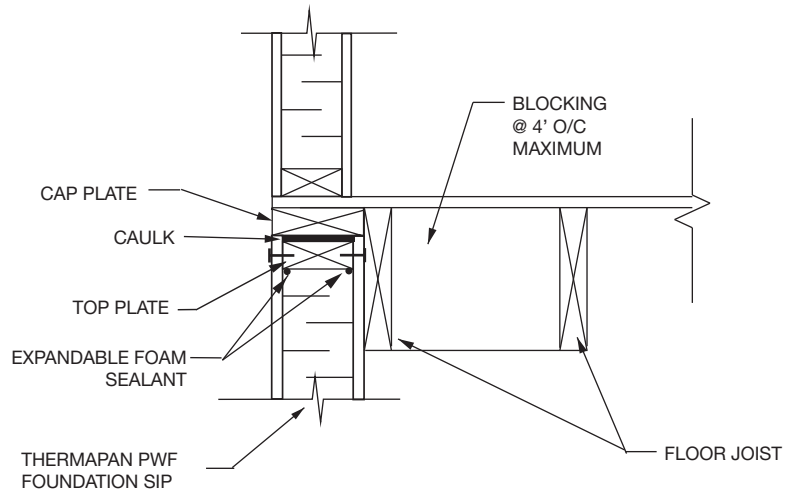

NOTES: REFER TO AIR BARRIER (AB-1) DETAILS FOR SEALING SIP CONNECTIONS.

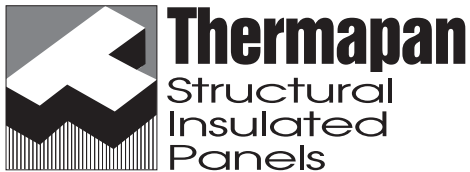

www.thermapan.com
1-877-443-WALL (9255)

TITLE		PROJECT	
SUSPENDED (HUNG) FLOOR CONNECTIONS (END WALLS)		PROJECT	
		REFERENCE	SCALE
DATE		REVISION	DWG. NO.
FEBRUARY 2012		2	FO-12
		N.T.S.	

STANDARD FLOOR JOIST

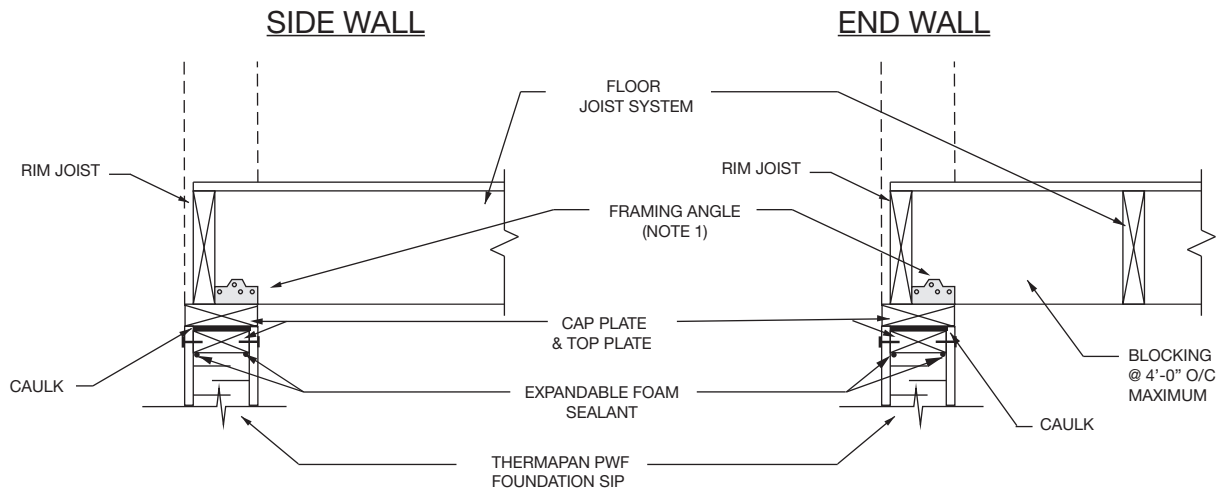

WOOD-I FLOOR JOIST (INSTALLATION TO BE CONFIRMED BY JOIST MANUFACTURER)

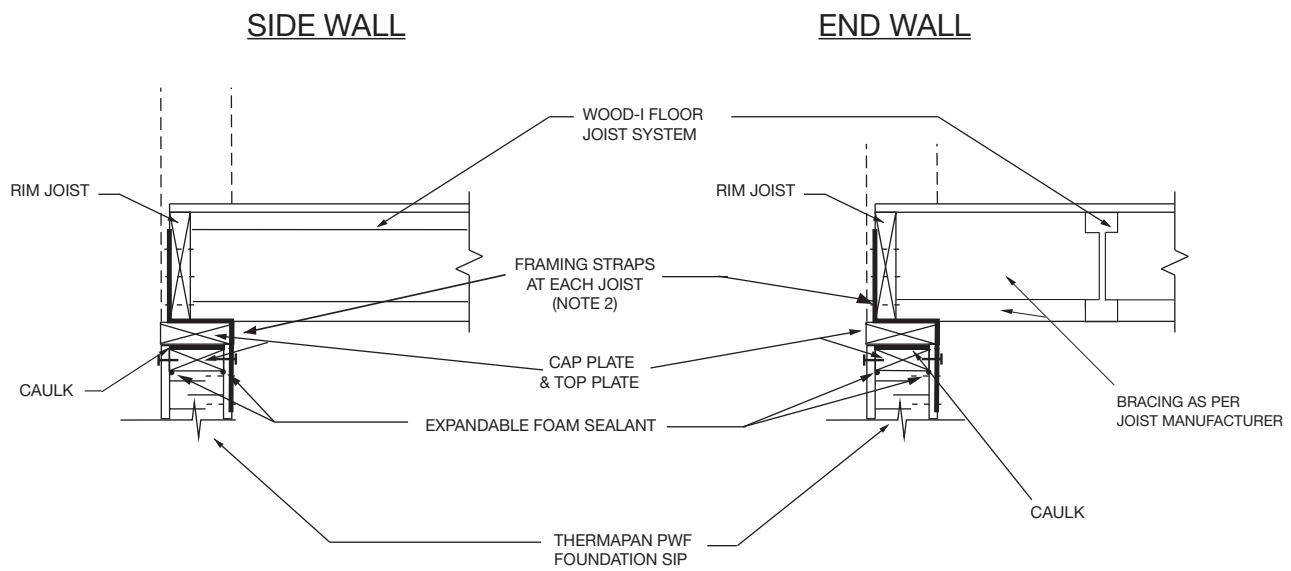

- NOTES:
1. SIMPSON A34 OR EQUAL (GALVANIZED)
 2. 1.5"x16" 20 GAUGE (GALVANIZED)

REFER TO AIR BARRIER (AB-1) DETAILS FOR SEALING SIP CONNECTIONS.

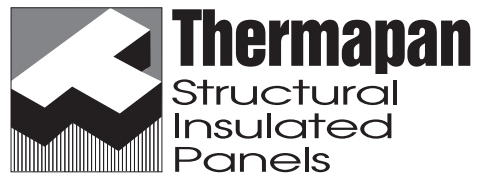

www.thermapan.com
1-877-443-WALL (9255)

TITLE		PROJECT	
PLATFORM FLOOR CONNECTIONS			
REFERENCE	SCALE		
	N.T.S.		
DATE	REVISION	DWG. No.	
JANUARY 2021	4	FO-13	

STAIRWELL OPENING PERPENDICULAR TO SIDE WALL

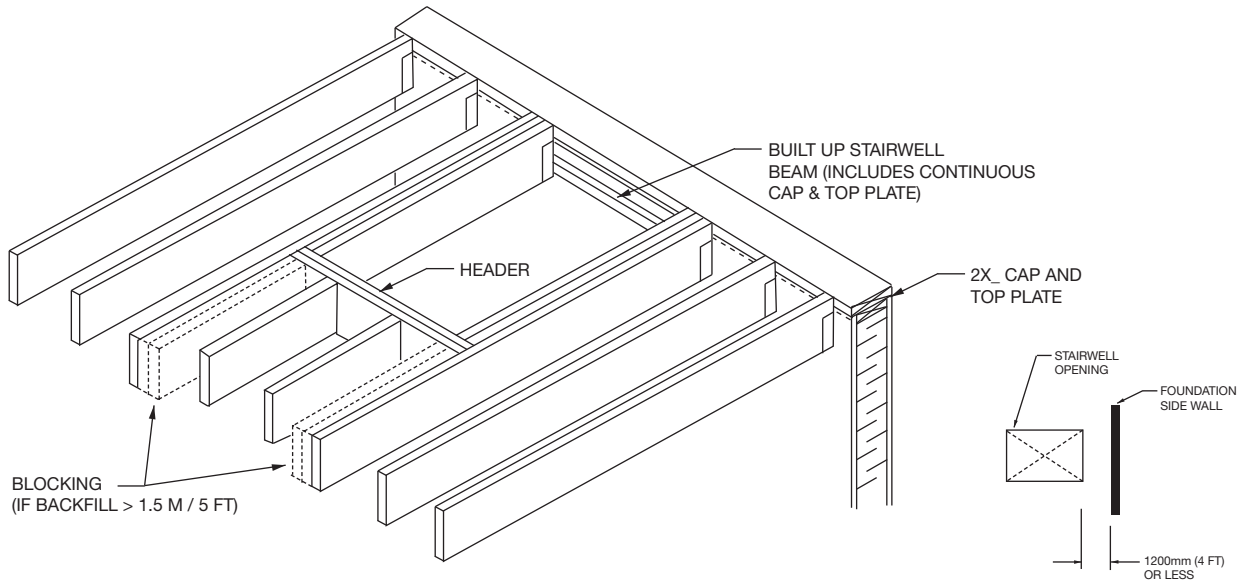

STAIRWELL OPENING PARALLEL TO END WALL

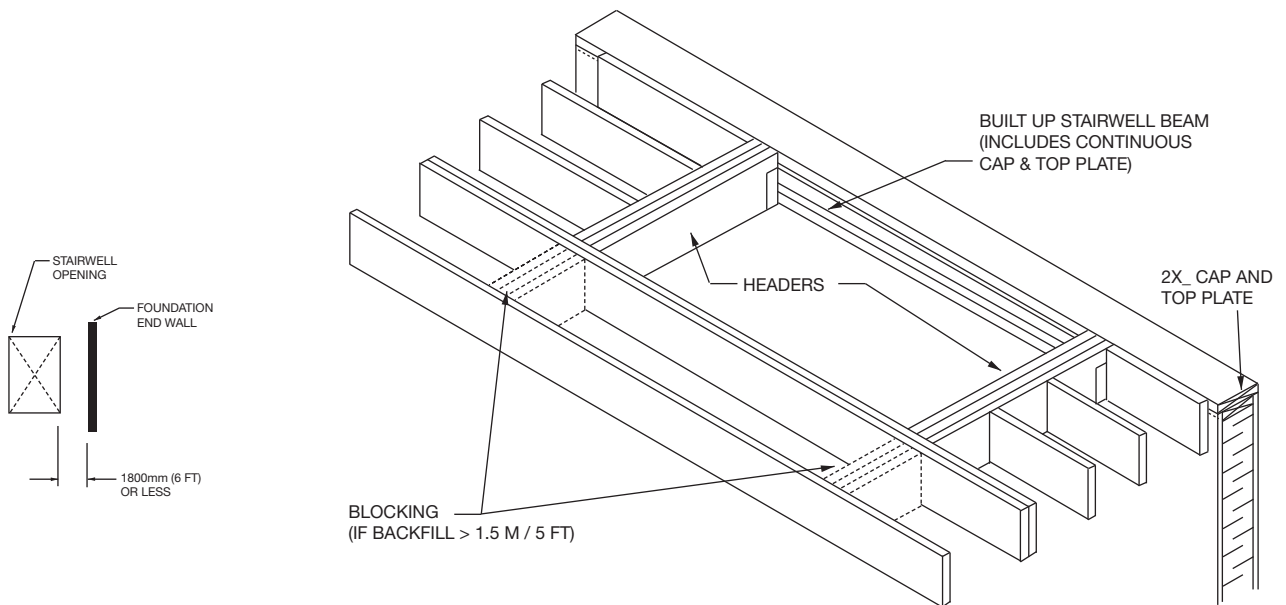

NOTES: ABOVE DETAILS APPLY TO OPENINGS LESS THAN 1200mm (4 FT) FROM A SIDE WALL OR LESS THAN 1800mm (6 FT) FROM AN END WALL. OPENINGS FURTHER THAN THESE MEASUREMENTS CAN BE FRAMED AS PER STANDARD FRAMING METHODS



www.thermapan.com
1-877-443-WALL (9255)

TITLE		PROJECT	
STAIRWELL OPENINGS			
REFERENCE	SCALE		
	N.T.S.		
DATE	REVISION	DWG. NO.	
MAY 2011	1	FO-14	

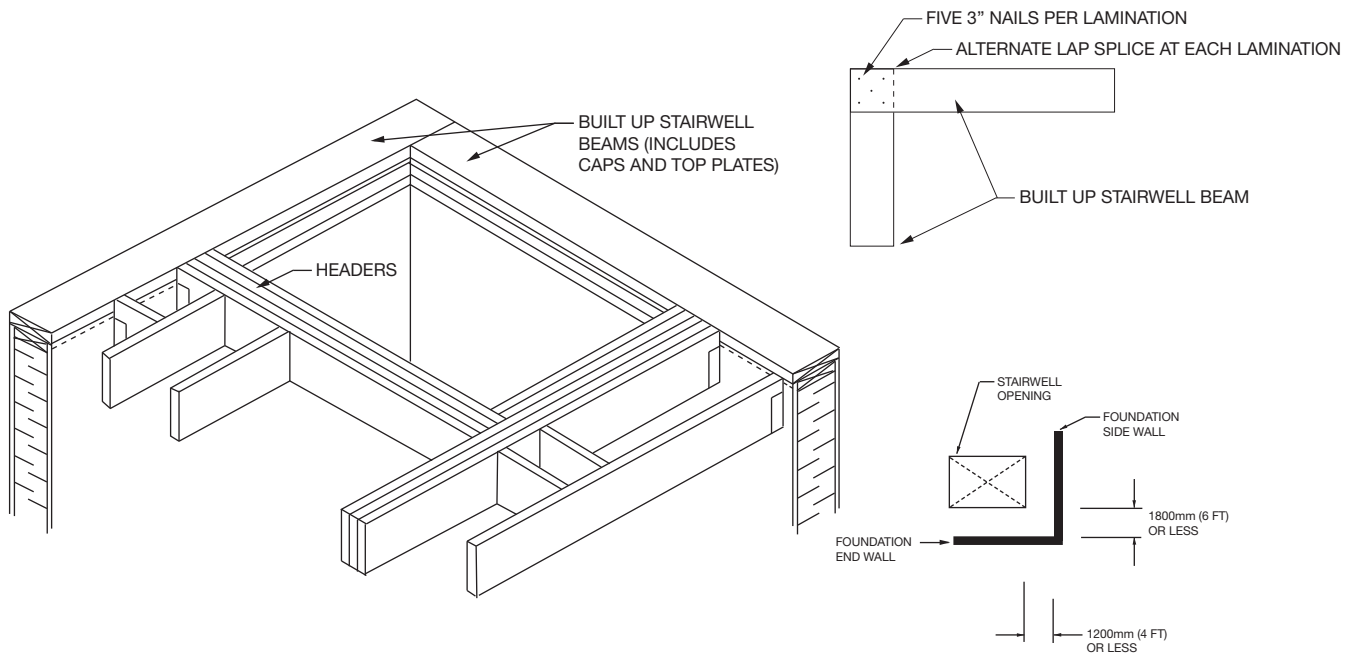

FRAMING FOR FLOOR OPENINGS GREATER THAN 1200mm (4 ft) IN OPENING WIDTH
 (WOOD SLEEPER OR CONCRETE SLAB FLOOR TYPES)

Stairwell Opening Width*	Backfill Height (Max)	Number of Stairwell Beam Laminations			Minimum No. of Joist Headers	Maximum spacing for subfloor joist header and trimmer joist nailing, 76 mm (3") nails
		2x6	2x8	2x10		
≤ 3200 mm 10'6"	1500 mm (6'0")	3	2	-	2	2 rows, 150 mm (6") centres
	2300 mm (7'6")	9	6	4	3	2 rows, 50 mm (2") centres
	2900 mm (9'6")	-	10	7	3	2 rows, 50 mm (2") centres
≤ 3600 mm 12'0"	1500 mm (6'0")	3	3	2	2	2 rows, 150 mm (6") centres
	2300 mm (7'6")	11	8	5	3	2 rows, 50 mm (2") centres
	2900 mm (9'6")	-	12	8	3	2 rows, 50 mm (2") centres
≤ 4300 mm 14'0"	1500 mm (6'0")	5	3	2	2	2 rows, 150 mm (6") centres
	2300 mm (7'6")	-	11	8	3	2 rows, 50 mm (2") centres
	2900 mm (9'6")	-	-	12	3	2 rows, 50 mm (2") centres

NOTES: ABOVE DETAILS AND TABLE APPLY TO OPENINGS LESS THAN 1200mm (4 FT) FROM A SIDE WALL OR LESS THAN 1800mm (6 FT) FROM AN END WALL. OPENINGS FURTHER THAN THESE MEASUREMENTS CAN BE FRAMED AS PER STANDARD FRAMING METHODS.

* THE WIDTH IS MEASURED PARALLEL TO THE FOUNDATION WALL. THE REQUIREMENTS OF THIS TABLE SHALL APPLY AS APPROPRIATE TO A STAIRWELL BEAM LYING IN THE DIRECTION OF MEASUREMENT. IN THE CASE OF A STAIRWELL CORNER OPENING, THE TABULATED WIDTH AND FRAMING REQUIREMENTS SHALL BE APPLIED SEPARATELY AND INDEPENDENTLY IN BOTH MAJOR DIRECTIONS.

** JOIST HEADERS WHICH EXCEED 3200 mm (10'6") IN UNSUPPORTED LENGTH SHALL ALSO BE SIZED BY CALCULATION OR MAY BE DETERMINED FROM TABLES FOR BUILTUP FLOOR BEAMS.



www.thermapan.com
 1-877-443-WALL (9255)

TITLE		CORNER STAIRWELL OPENINGS & FRAMING TABLE		PROJECT
REFERENCE	SCALE		N.T.S.	
DATE	REVISION	DWG. NO.		
MAY 2011	1	FO-15		

TOP PLAN

ELEVATION

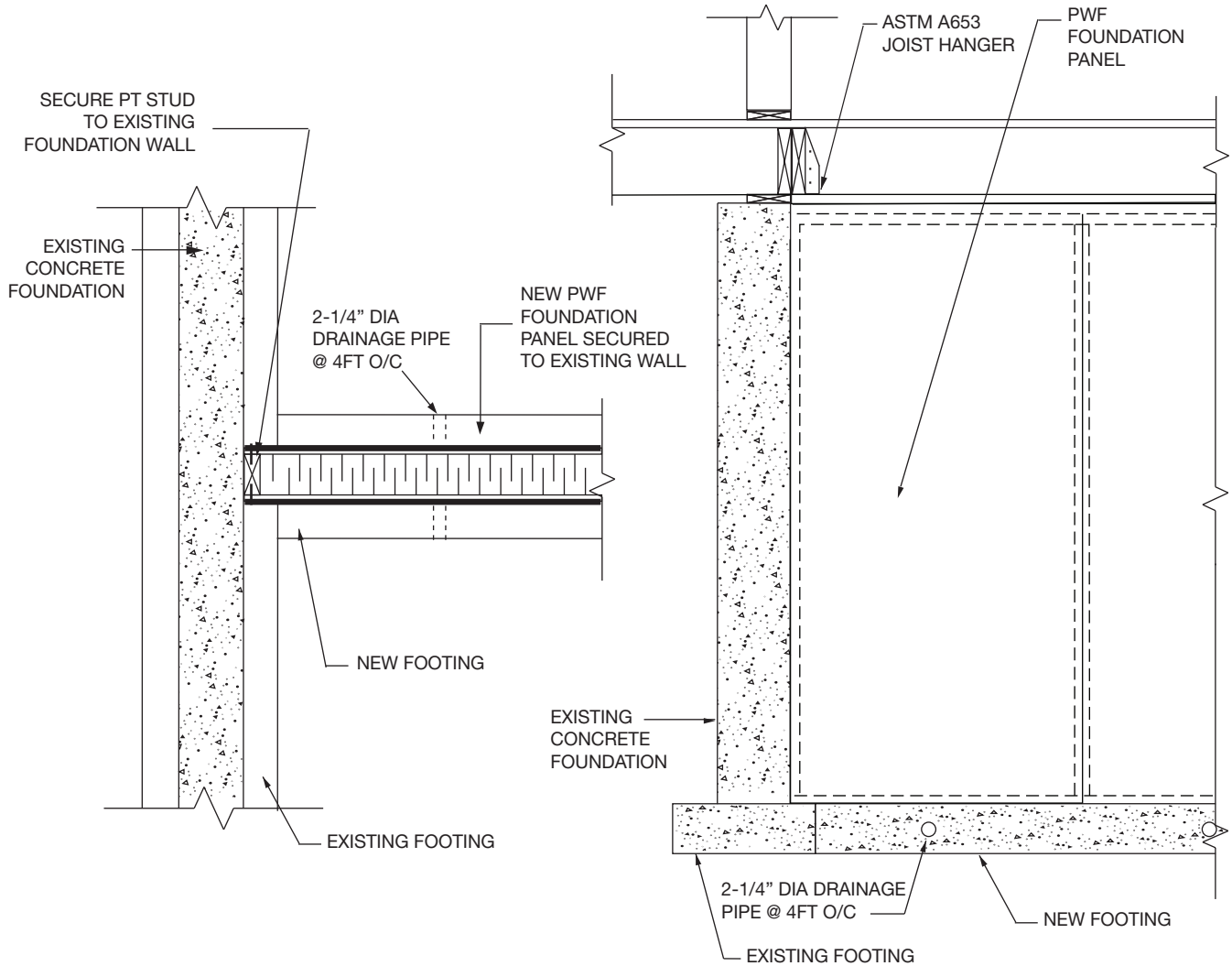

NOTE: THE ADHERENCE OF ANY WATER-PROOFING MEMBRANE TO ANY THERMAPAN SIP PWF PLYWOOD SURFACE WILL VOID THE THERMAPAN WARRANTY.



www.thermapan.com
1-877-443-WALL (9255)

TITLE		PROJECT	
FASTENING PWF WALL TO EXISTING FOUNDATION			
REFERENCE	SCALE	N.T.S.	
DATE	REVISION	DWG. NO.	
FEBRUARY 2012	2	FO-16	

ISOMETRIC VIEW
(FINISHING NOT SHOWN)

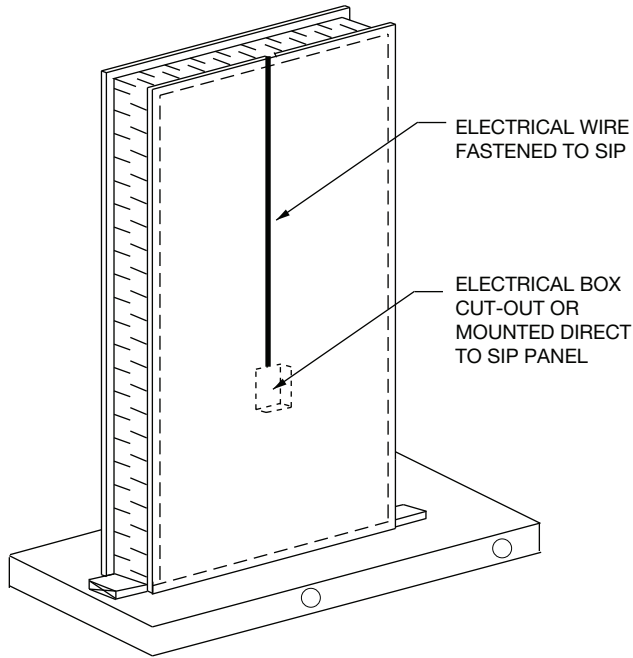

TOP PLAN

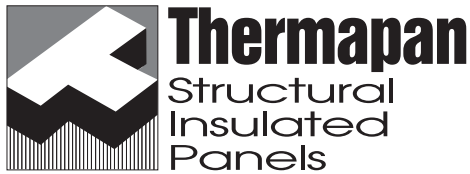
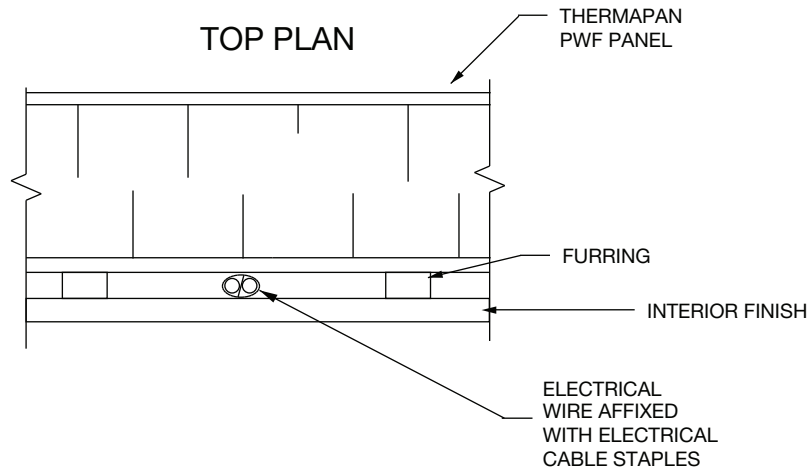

www.thermapan.com
1-877-443-WALL (9255)

TITLE		PROJECT	
ELECTRICAL INSTALLATION		PROJECT	
		PROJECT	
REFERENCE	SCALE		PROJECT
	N.T.S.		
DATE	REVISION	DWG. No.	PROJECT
FEBRUARY 2016	4	FO-17	

PWF BASEMENT WALL ALIGNED WITH FROST WALL

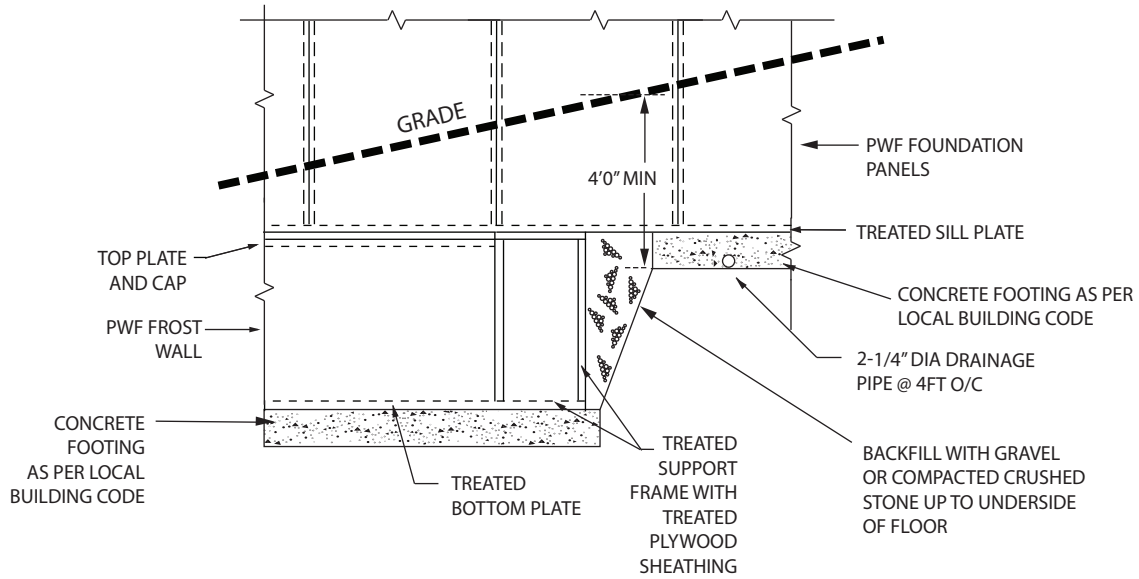

SIP FOUNDATION TO GARAGE FOUNDATION

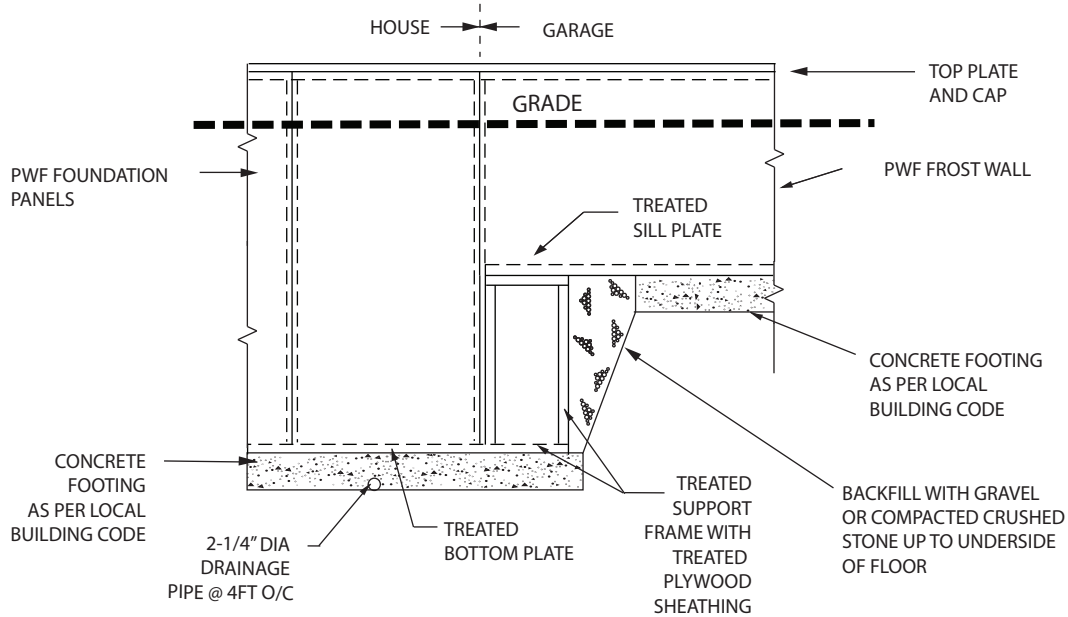

NOTE: THE ADHERENCE OF ANY WATER-PROOFING MEMBRANE TO ANY THERMAPAN SIP PWF PLYWOOD SURFACE WILL VOID THE THERMAPAN WARRANTY.



www.thermapan.com
1-877-443-WALL (9255)

TITLE		PROJECT	
BASEMENT PWF WALL CONNECTION TO FROST WALL			
REFERENCE	SCALE		
	N.T.S.		
DATE	REVISION	DWG. NO.	
SEPTEMBER 2018	4	FO-18	

FOUNDATION WALL ELEVATION

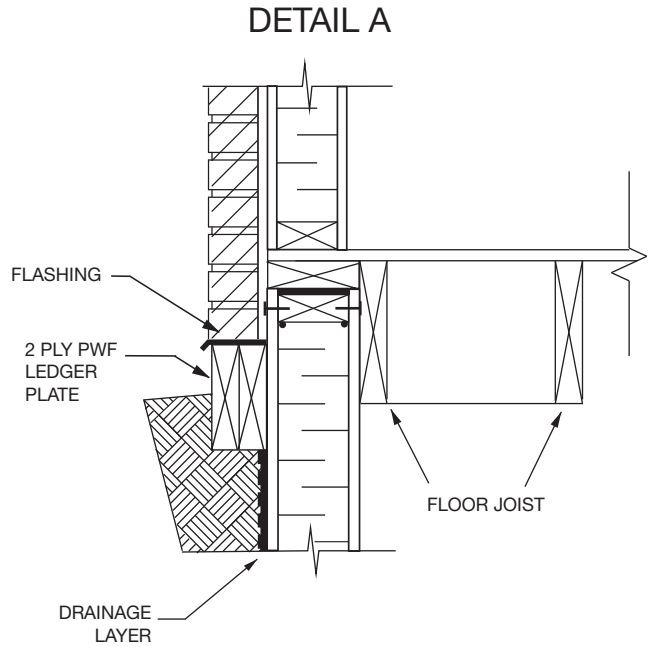
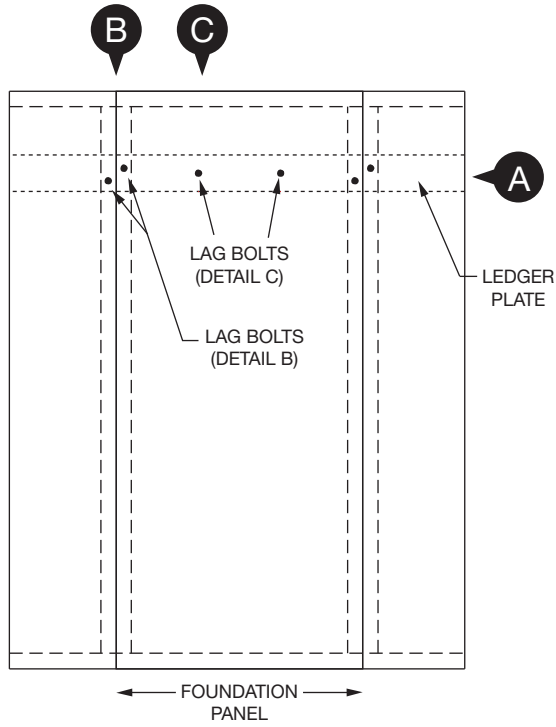

**DETAIL B
(TOP VIEW AT STUD SPLINE)**

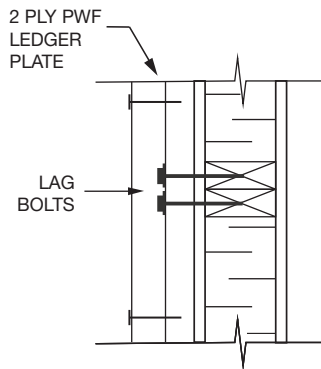

**DETAIL C
(TOP VIEW WITHIN PANEL)**

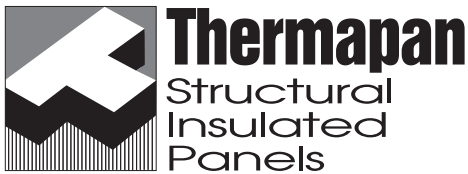
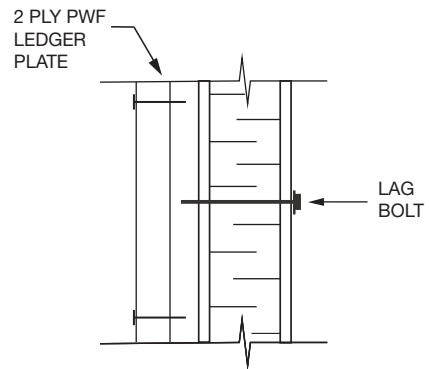

www.thermapan.com
1-877-443-WALL (9255)

TITLE		BRICK LEDGER DETAIL SECURED TO SIP FOUNDATION		PROJECT
REFERENCE	SCALE		N.T.S.	
DATE	REVISION	DWG. NO.		
JUNE 2020		FO-19		

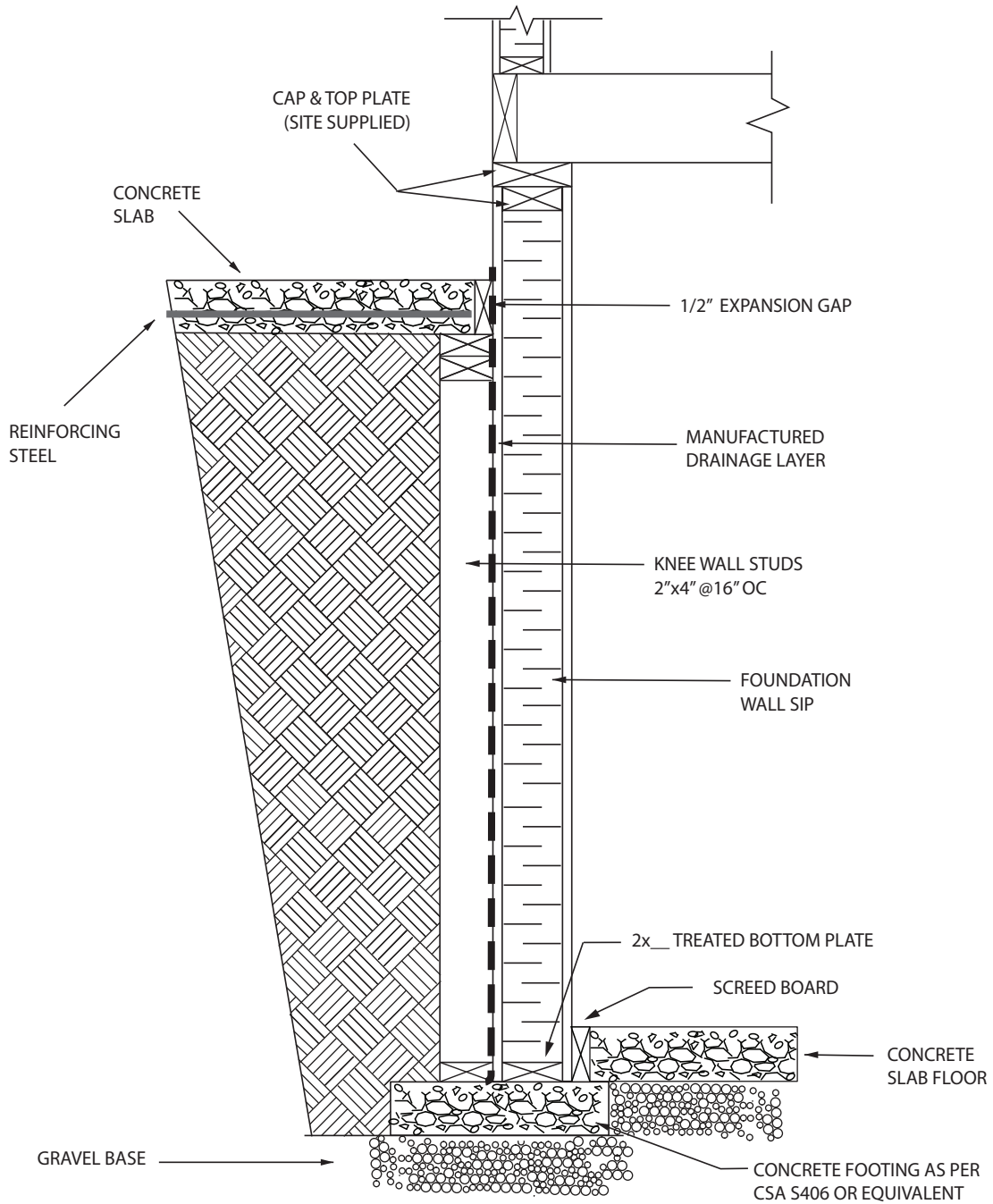

NOTE: THE ADHERENCE OF ANY WATER-PROOFING MEMBRANE TO ANY THERMAPAN SIP PWF PLYWOOD SURFACE WILL VOID THE THERMAPAN WARRANTY.

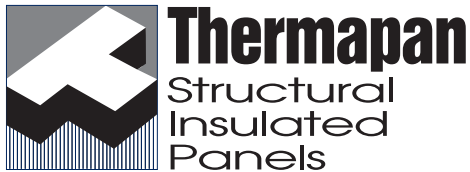

www.thermapan.com
1-877-443-WALL (9255)

TITLE		PROJECT	
SURCHARGE FROM DRIVEWAY SLAB OR PATIO SLAB			
REFERENCE	SCALE		
	N.T.S.		
DATE	REVISION	DWG. No.	
JANUARY 2021		FO-20	

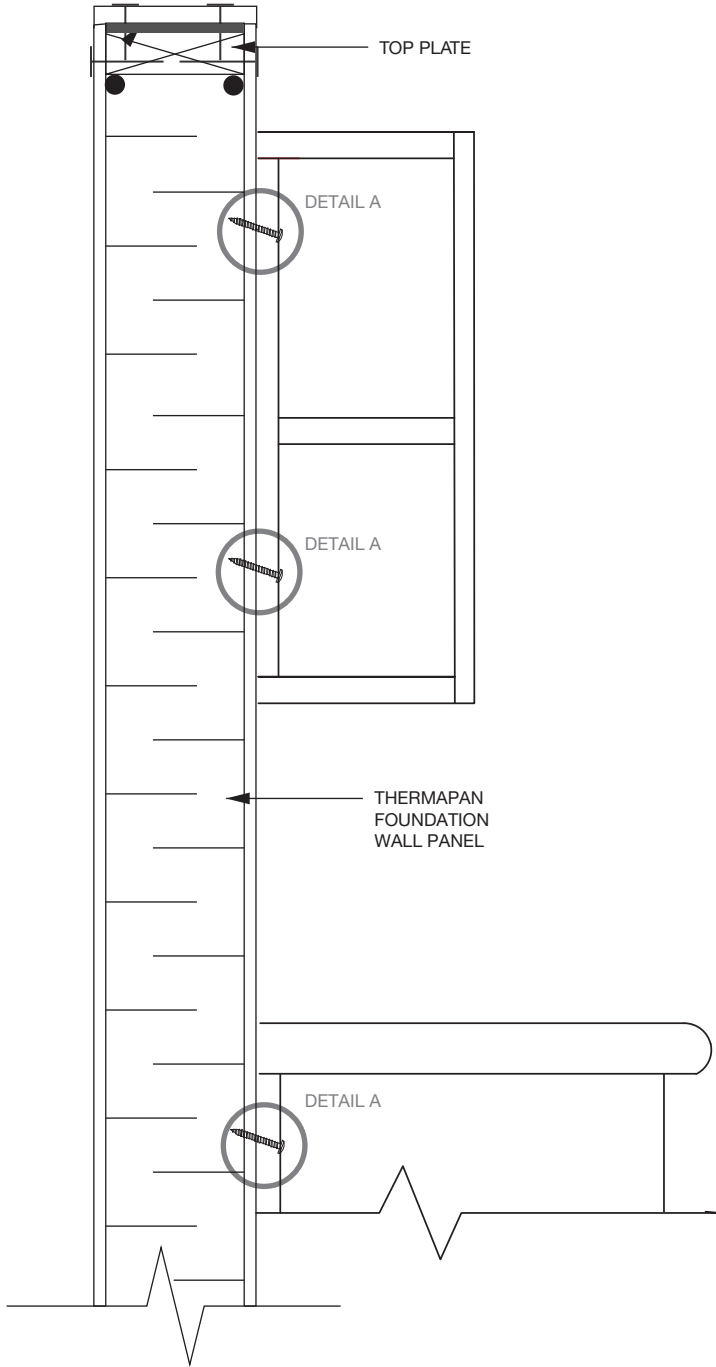

DETAIL A

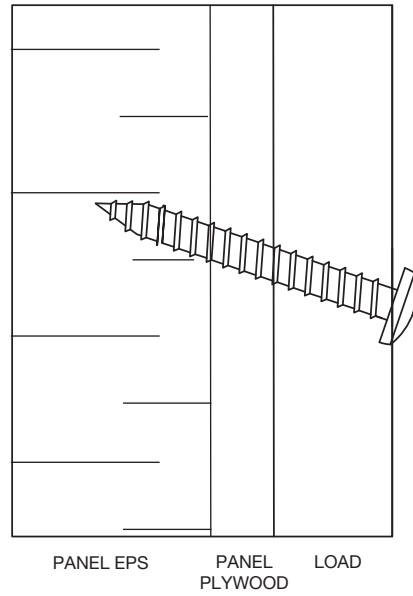

NOTE: NUMBER 10 TYPE A SHEET METAL SCREWS CAN RESIST A PULL OUT OF 120 POUNDS IN PLYWOOD. CONTRACTOR TO CONFIRM LOAD TO BE SECURED AND NUMBER OF FASTENERS REQUIRED. FULL THICKNESS OF PLYWOOD TO RECEIVE SCREW THREAD ON ANGLE AS DETAILED

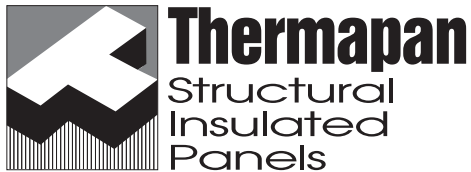

www.thermapan.com
1-877-443-WALL (9255)

TITLE		PROJECT	
SCREW FASTENER DETAIL FOR SECURING SHELVING TO FOUNDATION PANEL			
REFERENCE	SCALE		
	N.T.S.		
DATE	REVISION	DWG. No.	
FEBRUARY 2020		FO-21	

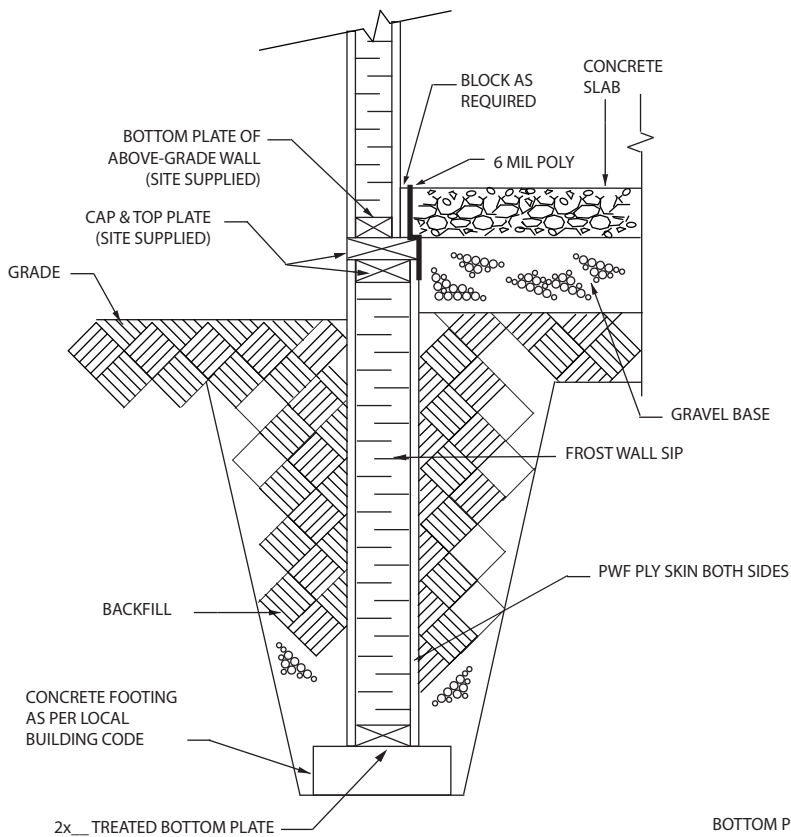

TYPICAL FROST WALL FOUNDATION SECTION

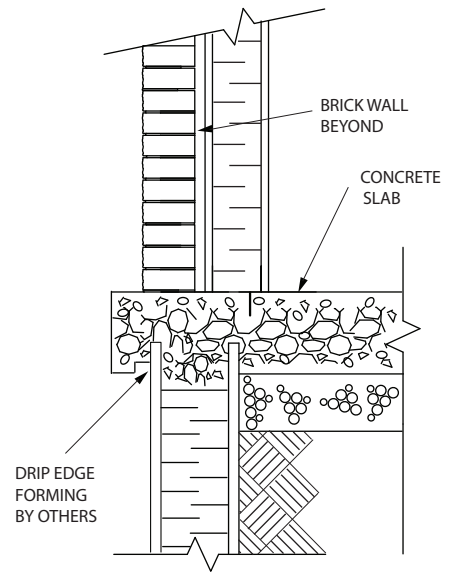

GARAGE DOOR FLOOR DETAIL SECTION

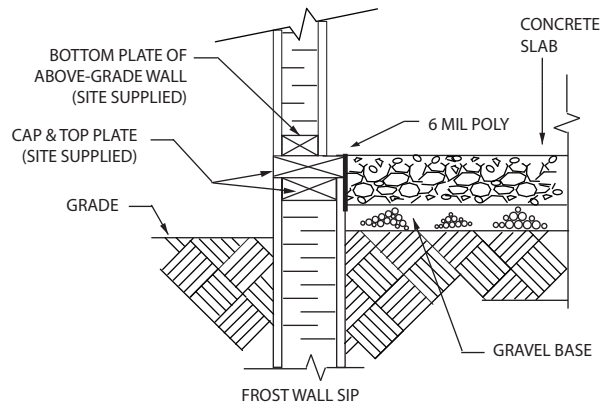

OPTION: TOP OF SLAB FLUSH OR BELOW TOP OF FROST WALL

NOTE: THE ADHERENCE OF ANY WATER-PROOFING MEMBRANE TO ANY THERMAPAN SIP PWF PLYWOOD SURFACE WILL VOID THE THERMAPAN WARRANTY.



www.thermapan.com
1-877-443-WALL (9255)

TITLE		PROJECT	
FROST WALL DETAILS			
REFERENCE	SCALE	N.T.S.	
DATE	REVISION	DWG. No.	
SEPTEMBER 2018	3	FW-1	

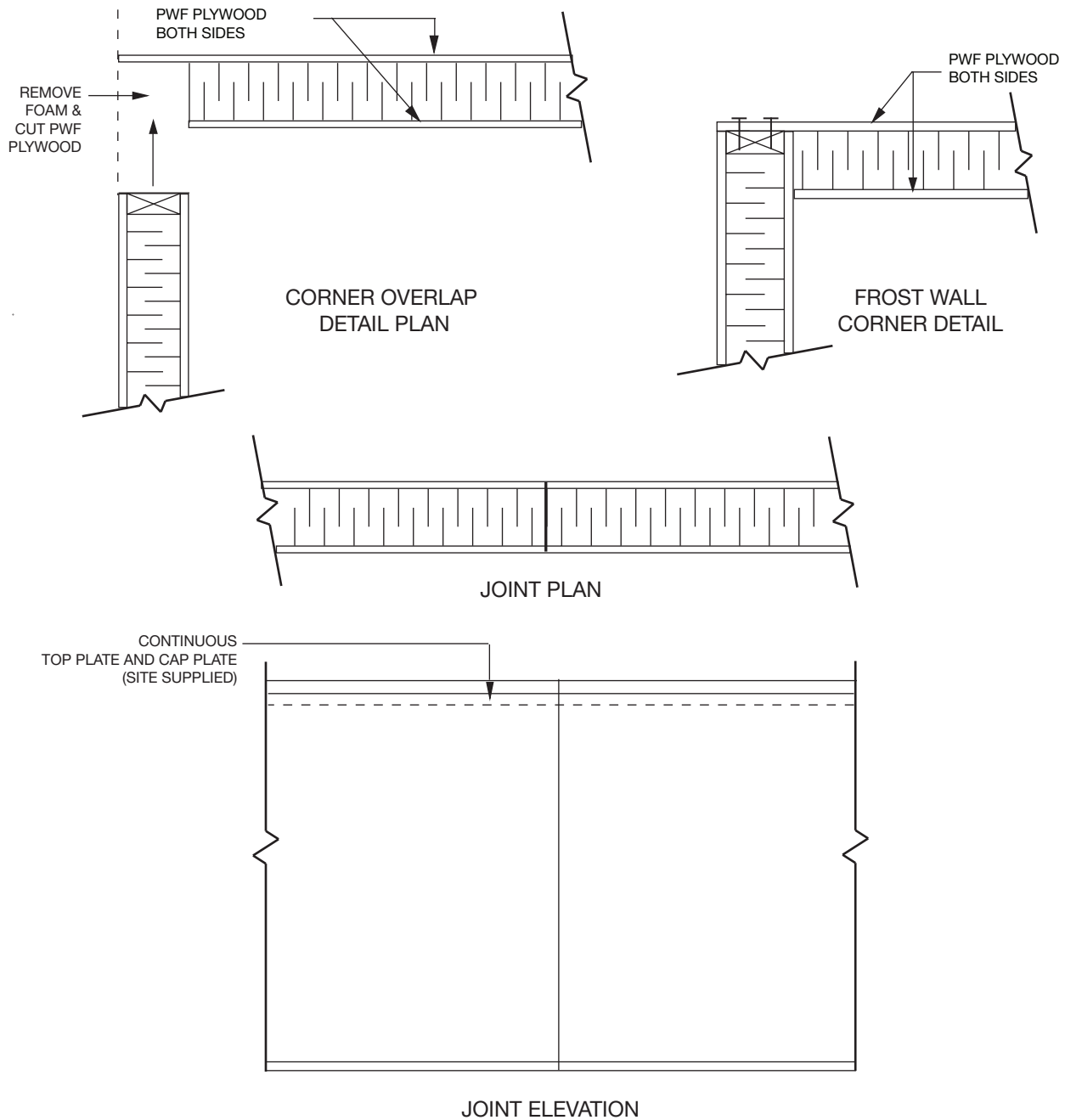

NOTE: THE ADHERENCE OF ANY WATER-PROOFING MEMBRANE TO ANY THERMAPAN SIP PWF PLYWOOD SURFACE WILL VOID THE THERMAPAN WARRANTY.



www.thermapan.com
1-877-443-WALL (9255)

TITLE		PROJECT	
FROST WALL PANEL CONNECTIONS		PROJECT	
REFERENCE	SCALE		
	N.T.S.		
DATE	REVISION	DWG. No.	
MARCH 2025	4	FW-2	

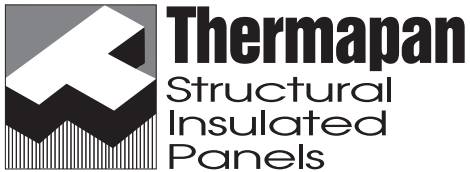
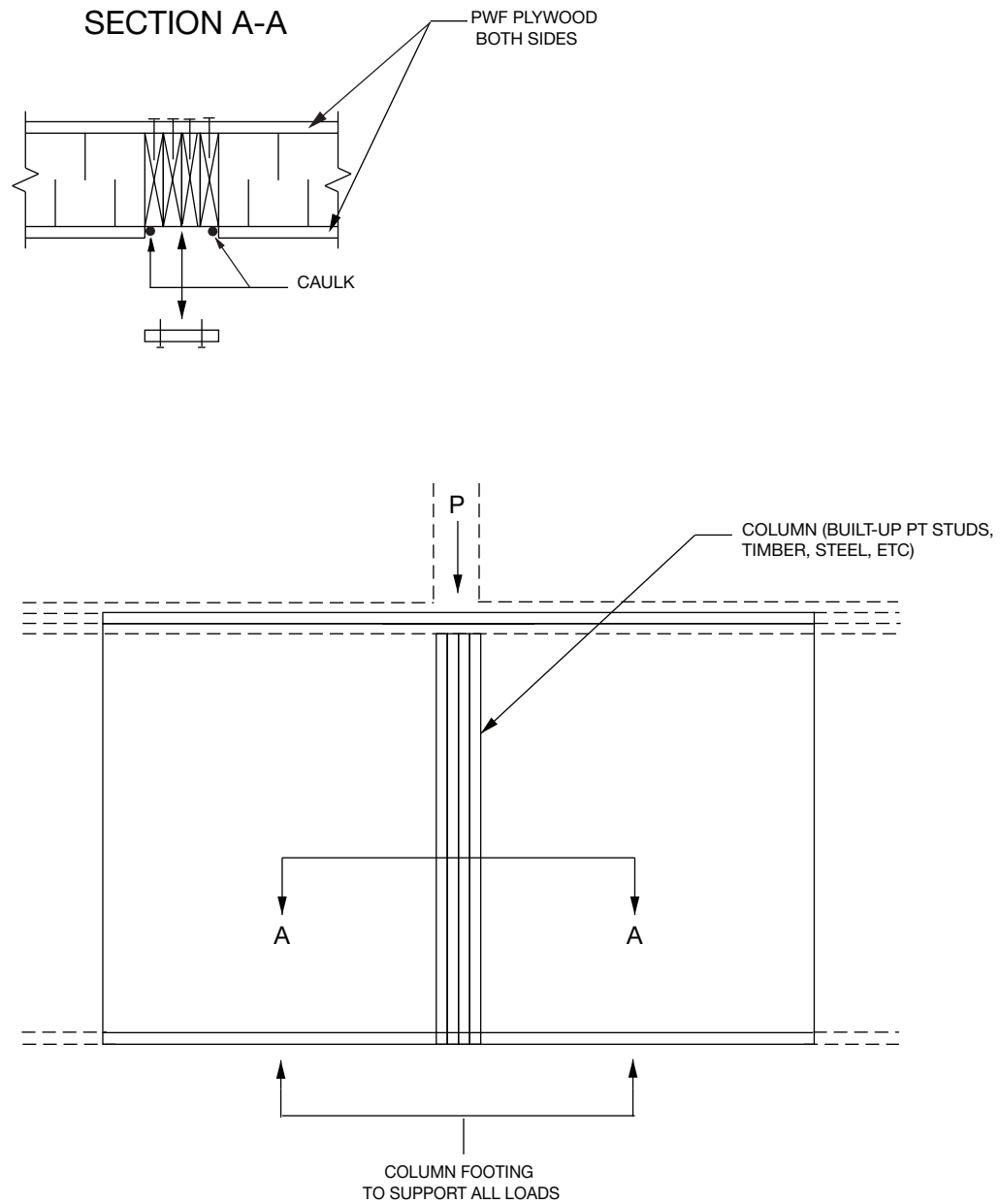

www.thermapan.com
1-877-443-WALL (9255)

TITLE		PROJECT	
REFERENCE		SCALE	
		N.T.S.	
DATE	REVISION	DWG. No.	
MARCH 2025	3	FW-3	

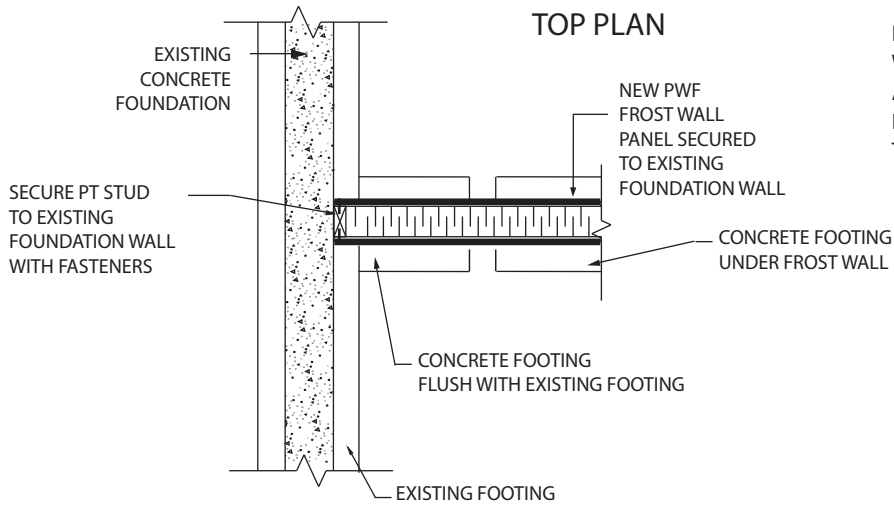

NOTE: THE ADHERENCE OF ANY WATER-PROOFING MEMBRANE TO ANY THERMAPAN SIP PWF PLYWOOD SURFACE WILL VOID THE THERMAPAN WARRANTY.

ELEVATION - NEW GARAGE FOUNDATION

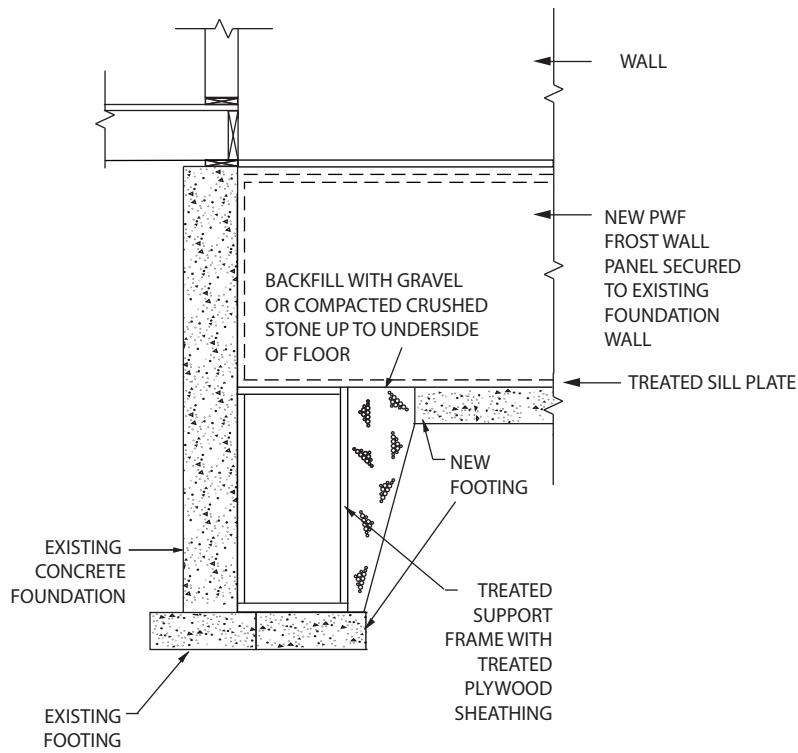

www.thermapan.com
1-877-443-WALL (9255)

TITLE		PROJECT	
FASTENING PWF FROST WALL TO EXISTING FOUNDATION			
REFERENCE	SCALE		
	N.T.S.		
DATE	REVISION	DWG. NO.	
SEPTEMBER 2018	3	FW-4	

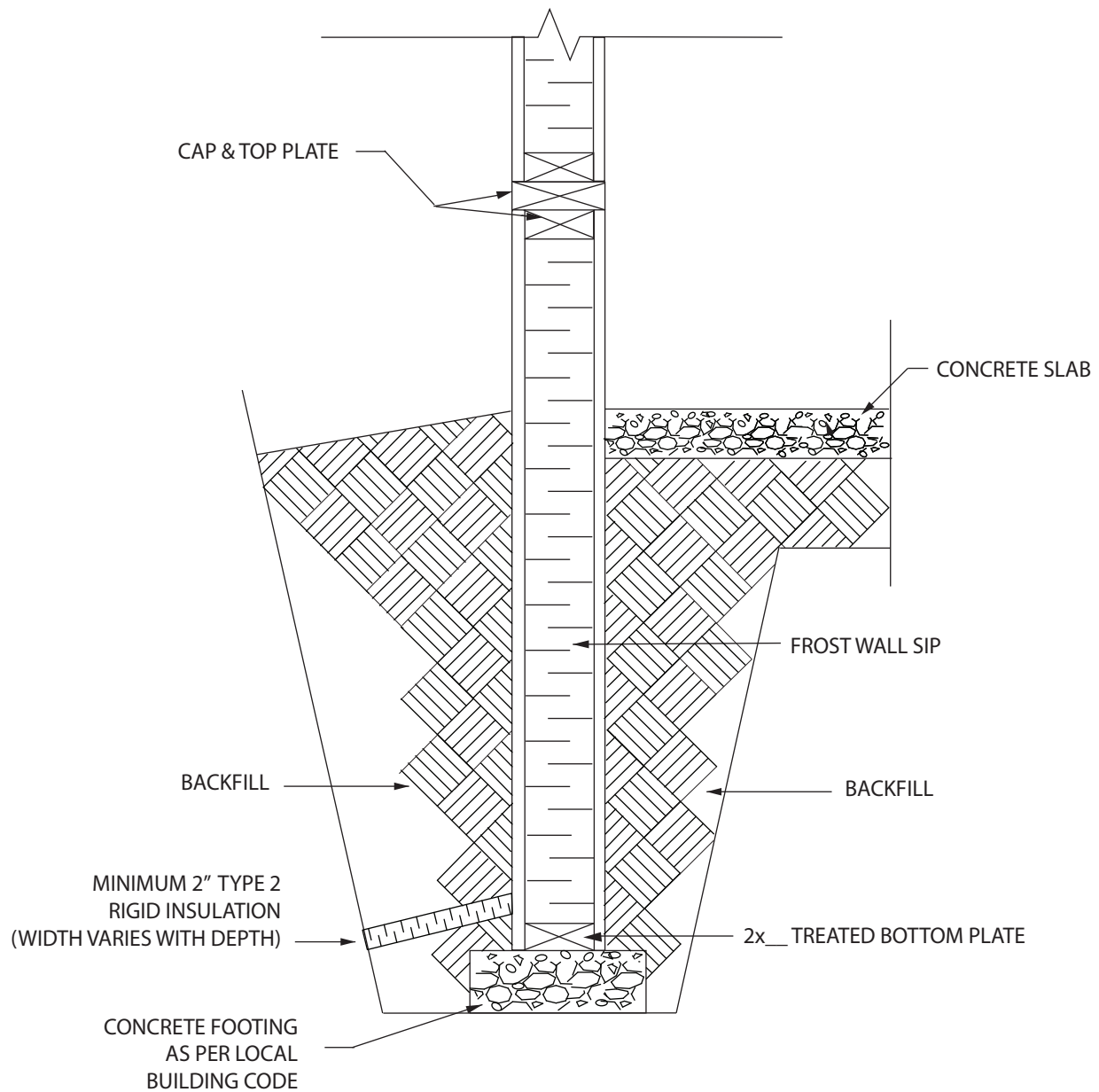

NOTE: THE ADHERENCE OF ANY WATER-PROOFING MEMBRANE TO ANY THERMAPAN SIP PWF PLYWOOD SURFACE WILL VOID THE THERMAPAN WARRANTY.

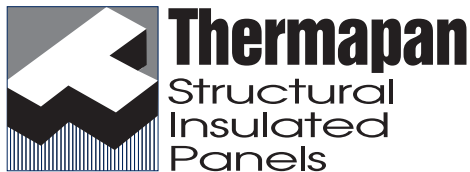

www.thermapan.com
1-877-443-WALL (9255)

TITLE		PROJECT	
REFERENCE		SCALE	
		N.T.S.	
DATE		REVISION	DWG. No.
APRIL 2020		1	FW-5